

e 602-II

Cardioid microphone for low frequency instruments

FEATURES

- Rugged, lightweight aluminium body for stable positioning on long microphone boom arms
- Lightweight high-performance voice coil construction
- Fast transient response
- Low frequency extension
- Ideal for direct use on the most problematic bass signal sources
- Frequency-independent directivity provides isolation from other on-stage signals
- Hum compensating coil
- Integral stand mount

The **e 602 II** is a cardioid instrument microphone especially suitable for use with bass drums, bass guitar cabs, tubas and other low frequency instruments.



ARCHITECT'S SPECIFICATIONS

The microphone shall be a dynamic cardioid designed for use with low frequency instruments. It shall have a rugged aluminium body with an integral stand mount and shall be fitted with a hum compensating coil.

The frequency response shall be 20 Hz–16,000 Hz and the sensitivity (free field, no load) shall be 0.25 mV/Pa at 1 kHz and 0.9 mV/Pa at 50 Hz. Nominal impedance shall be 350 Ω, with a min. terminating impedance of 1 kΩ.

The microphone shall provide a 3-pin XLR connector. Dimensions shall be 60 x 153 mm (2.36" x 6.02"). Weight shall be 318 grams (11.22 oz). The microphone shall be the Sennheiser e 602-II.

TECHNICAL DATA

Transducer principle	dynamic
Pick-up pattern.....	cardioid
Frequency response	20 – 16,000 Hz
Sensitivity (free field, no load)	0.25 mV/Pa (at 1 kHz) / 0.9 mV/Pa (at 50 Hz)
Nominal impedance.....	350 Ohm
Min. terminating impedance	1000 Ohm
Connector.....	XLR-3
Dimensions	∅ 60 x 153 mm
Weight.....	318 g

DELIVERY INCLUDES

- 1 e 602-II
- 1 Pouch
- Instructions for use

e 602-II Cardioid microphone for low frequency instruments

FREQUENCY RESPONSE

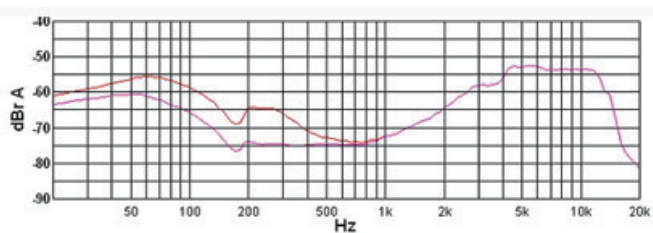

POLAR PATTERN

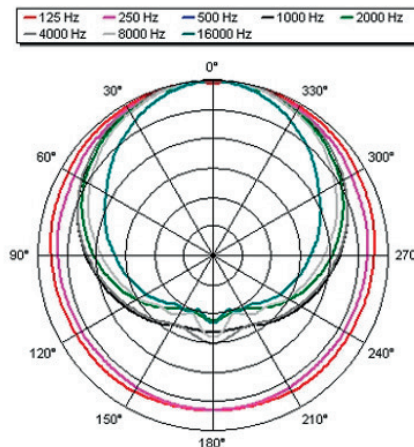

DIMENSIONS

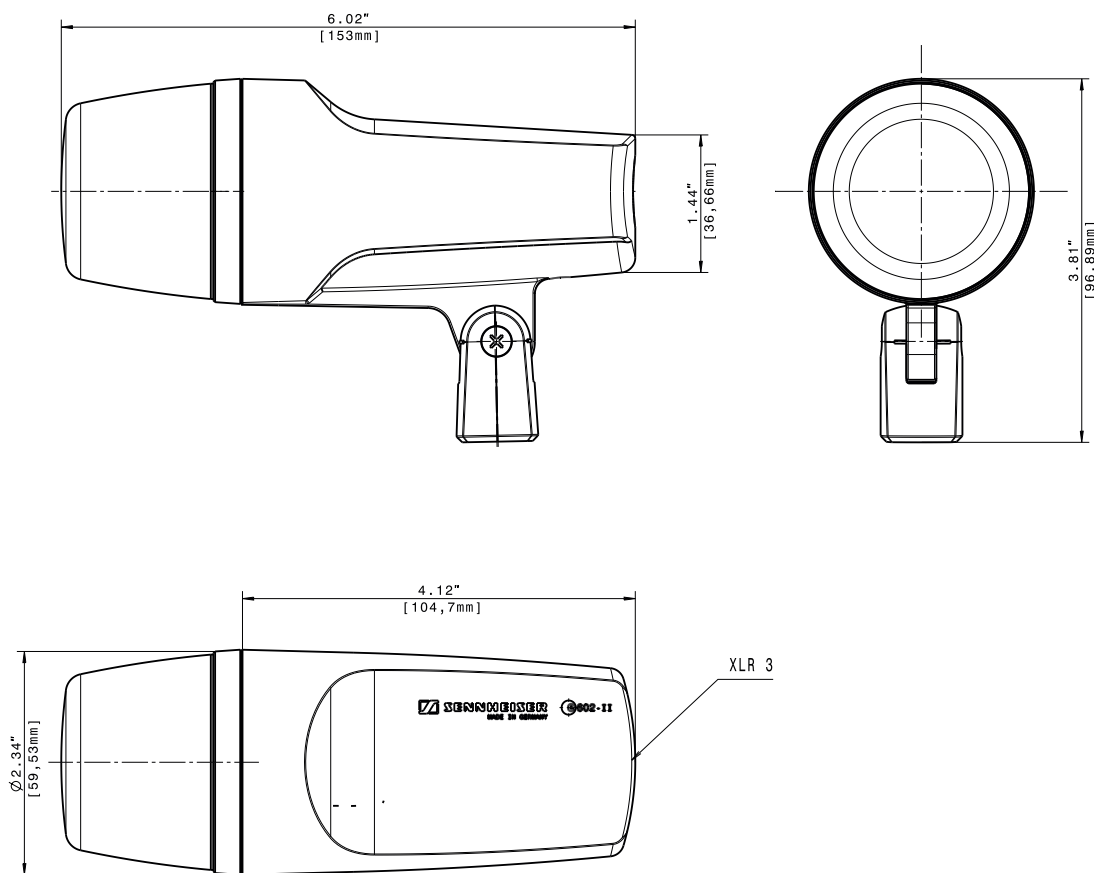

Sennheiser electronic GmbH & Co. KG
 Am Labor 1, 30900 Wedemark, Germany
www.sennheiser.com

SENNHEISER