

Controller for Octostrip FLEX

Product code: 42240

Preface

Thank you for purchasing this Showtec product.

The purpose of this user manual is to provide instructions for the correct and safe use of this product.

Keep the user manual for future reference as it is an integral part of the product. The user manual shall be stored at an easily accessible location.

This user manual contains information concerning:

- Safety instructions
- Intended and non-intended use of the device
- Installation and operation of the device
- Maintenance procedures
- Troubleshooting
- Transport, storage and disposal of the device

Non-observance of the instructions in this user manual may result in serious injuries and damage of property.

©2025 Showtec. All rights reserved.

No part of this document may be copied, published or otherwise reproduced without the prior written consent of Highlite International.

Design and product specifications are subject to change without prior notice.

For the latest version of this document or other language versions, please visit our website www.highlite.com or contact us at service@highlite.com.

Highlite International and its authorized service providers are not liable for any injury, damage, direct or indirect loss, consequential or economic loss or any other loss arising from the use of, or inability to use or reliance on the information contained in this document.

Highlite International B.V. – Vestastraat 2 – 6468 EX Kerkrade – the Netherlands

Table of contents

1. Introduction	4
1.1. Before Using the Product.....	4
1.2. Intended Use.....	4
1.3. Product Lifespan.....	4
1.4. Text Conventions.....	4
1.5. Symbols and Signal Words.....	5
1.6. Symbols on the Information Label.....	5
2. Safety	6
2.1. Warnings and Safety Instructions.....	6
2.2. Requirements for the User.....	8
2.3. Personal Protective Equipment.....	8
3. Description of the Device	9
3.1. Front View.....	9
3.2. Back View.....	9
3.3. Product Specifications.....	10
3.4. Optional Accessories.....	11
3.5. Compatibility.....	11
3.6. Dimensions.....	11
4. Installation	12
4.1. Safety Instructions for Installation.....	12
4.2. Personal Protective Equipment.....	12
4.3. Installation Site Requirements.....	12
4.4. Rigging.....	13
4.4.1. Installation with a Clamp.....	13
4.4.2. Installation on a Flat Surface.....	14
4.5. Connecting LED Strips to the Controller.....	15
4.6. Connecting to Power Supply.....	15
4.7. Power Linking of Multiple Devices.....	16
5. Setup	17
5.1. Warnings and Precautions.....	17
5.2. Stand-alone Setup.....	17
5.3. DMX Connection.....	17
5.3.1. DMX-512 Protocol.....	17
5.3.2. DMX Cables.....	17
5.3.3. Master/Slave Setup.....	18
5.3.4. DMX Linking.....	19
5.3.5. DMX Addressing.....	19
5.4. Ethernet Connection.....	20
5.4.1. Art-Net/sACN Protocol.....	20
5.4.2. Network Cables.....	20
5.4.3. Art-Net/sACN Linking.....	21
5.4.4. Art-Net Settings.....	21
5.4.5. sACN Settings.....	21
5.4.6. Universe Numbering.....	22
6. Operation	23
6.1. Safety Instructions for Operation.....	23
6.2. Control Modes.....	23
6.3. Control Panel.....	24
6.4. Start-up.....	24
6.5. Menu Overview.....	25
6.6. Main Menu Options.....	27
6.6.1. DMX.....	27
6.6.1.1. Address.....	27
6.6.1.2. Channels.....	27
6.6.2. NetWork Configuration.....	28
6.6.2.1. Local IP.....	28
6.6.2.2. Subnet Mask.....	28

6.6.2.3.	ArtNet Universe.....	28
6.6.3.	Manual.....	29
6.6.3.1.	Color All.....	29
6.6.3.2.	Color Pixel.....	29
6.6.4.	Auto.....	29
6.6.5.	Program.....	30
6.6.6.	Slave.....	30
6.6.7.	Settings.....	30
6.6.7.1.	Patch.....	31
6.6.7.1.1.	Output 1-8.....	31
6.6.7.2.	Led Mode.....	31
6.6.7.3.	Curves Select.....	31
6.6.7.4.	Display Invert.....	32
6.6.7.5.	DMX Fail.....	32
6.6.7.6.	Lock.....	32
6.6.8.	Information.....	33
6.7.	DMX Channels.....	34
6.7.1.	DMX Channels Overview.....	34
6.7.1.1.	Strip and Section Control per DMX Personality.....	34
6.7.1.2.	Functions per DMX Personality.....	34
6.7.2.	9 Channels.....	34
6.7.3.	16 Channels.....	35
6.7.4.	30 Channels.....	35
6.7.5.	32 Channels.....	36
6.7.6.	58 Channels.....	37
6.7.7.	256 Channels – 1 m LED Strips.....	38
6.7.8.	128 Channels – 0,5 m LED Strips.....	44
6.7.9.	384 Channels – 1 m LED Strips.....	47
6.7.10.	192 Channels – 0,5 m LED Strips.....	57
6.7.11.	Built-in Programs Channel Overview.....	62
6.7.12.	Preset Colors Channel Overview.....	63
6.8.	RDM Information.....	64
6.8.1.	RDM Details.....	64
6.8.2.	Supported RDM PIDs (Parameter IDs).....	64
7.	Troubleshooting.....	65
8.	Maintenance.....	66
8.1.	Safety Instructions for Maintenance.....	66
8.2.	Preventive Maintenance.....	66
8.2.1.	Basic Cleaning Instructions.....	66
8.3.	Corrective Maintenance.....	66
9.	Deinstallation, Transportation and Storage.....	67
9.1.	Instructions for Deinstallation.....	67
9.2.	Instructions for Transportation.....	67
9.3.	Storage.....	67
10.	Disposal.....	67
11.	Approval.....	67

1. Introduction

1.1. Before Using the Product



Important
Read and follow the instructions in this user manual before installing, operating or servicing this product.

The manufacturer will not accept liability for any resulting damages caused by the non-observance of this manual.

After unpacking, check the contents of the box. If any parts are missing or damaged, contact your Highlite International dealer.

Figure 1

Your shipment includes:

- Showtec Controller for Octostrip FLEX
- Schuko to Power Pro True 1 cable (1,5 m)
- User manual

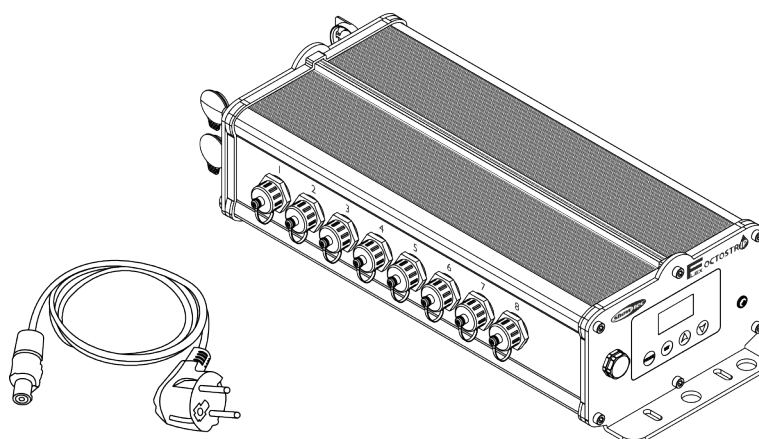

1.2. Intended Use

This device is intended for professional use as a controller. It can be installed indoors and outdoors. This device is not suitable for households and for general lighting.

Any other use, not mentioned under intended use, is regarded as non-intended and incorrect use.

1.3. Product Lifespan

This device is not designed for permanent operation.

Disconnect the device from the electrical power supply when the device is not in operation. This will reduce the wear and will improve the lifespan of the device.

1.4. Text Conventions

Throughout the user manual the following text conventions are used:

- Buttons: All buttons are in bold lettering, for example "Press the **UP/DOWN** buttons"
- References: References to parts of the device are in bold lettering, for example: "turn the **adjustment handle (05)**". References to chapters are hyperlinked
- 0–255: Defines a range of values
- Notes: **Note:** (in bold lettering) is followed by useful information or tips

1.5. Symbols and Signal Words

Safety notes and warnings are indicated throughout the user manual by safety signs.

Always follow the instructions provided in this user manual.



DANGER

Indicates an imminently hazardous situation which, if not avoided, will result in death or serious injury.



WARNING

Indicates a potentially hazardous situation which, if not avoided, could result in death or serious injury.



CAUTION

Indicates a potentially hazardous situation, which, if not avoided, may result in minor or moderate injury.



Attention

Indicates important information for the correct operation and use of the product.



Important

Read and observe the instructions in this document.



Electrical hazard



Thermal hazard



Provides important information about the disposal of this product.

1.6. Symbols on the Information Label

This product is provided with an information label. The information label is located on the side of the device.

The information label contains the following symbols:



This device shall not be treated as household waste.



Read and follow the instructions in the user manual before installing, operating or servicing the device.



This device falls under IEC protection class I.

IP65

This devices is rated IP65.



The surface and the inner parts of the device can become very hot during operation. Do not touch the device during operation.

2. Safety



Important
Read and follow the instructions in this user manual before installing, operating or servicing this product.

The manufacturer will not accept liability for any resulting damages caused by the non-observance of this manual.

2.1. Warnings and Safety Instructions



DANGER
Danger for children

For adult use only. The device must be installed beyond the reach of children.

- Do not leave any parts of the packaging (plastic bags, polystyrene foam, nails, etc.) within the reach of children. Packaging material is a potential source of danger for children.



DANGER
Electric shock caused by dangerous voltage inside

There are areas inside the device where dangerous touch voltage may be present.

- Do not open the device or remove any covers.
- Do not operate the device if the covers or the housing are open. Before operation, check if the housing is firmly closed and all screws are tightly fastened.
- Disconnect the device from the electrical power supply before service and maintenance, and when the device is not in use.



DANGER
Electric shock caused by short-circuit

This device falls under IEC protection Class I.

- Make sure that the device is electrically connected to ground (earth). Connect the device only to a socket-outlet with a ground (earth) connection.
- Do not cover the ground (earth) connection.
- Do not bypass the thermostatic switch or fuses.
- Do not let the power cable come into contact with other cables. Handle the power cable and all connections with the mains with caution.
- Do not modify, bend, mechanically strain, put pressure on, pull or heat up the power cable.
- Make sure that the power cable is not crimped or damaged. Examine the power cable periodically for any defects.
- Do not immerse the device in water or other liquids. Do not install the device in a location where flooding may occur.
- Do not use the device during thunderstorms. Disconnect the device from the electrical power supply immediately.
- Keep the connectors sealed with the rubber caps when the connectors are not in use.
- Do not connect the cables from above the connectors, if the device is installed outdoors. Make a 'drip loop' in the cable so that rain water cannot enter the device.



WARNING
Risk of burns due to hot surface

The surface and the inner parts of the device can become very hot during operation.

- Do not touch the device during operation.
- Allow the device to cool down for at least 15 minutes before handling.



Attention
Power supply

- Before connecting the device to the power supply, make sure that the current, voltage and frequency match the input voltage, current and frequency specified on the information label on the device.
- Make sure that the cross-sectional area of the extension cords and power cables is sufficient for the required power consumption of the device.



Attention
General safety

- Do not shake the device. Avoid brute force when installing or operating the device.
- If the device is dropped or struck, disconnect the device from the electrical power supply immediately.
- If the device is exposed to extreme temperature variations (e.g. after transportation), do not switch it on immediately. Let the device reach room temperature before switching it on, otherwise it may be damaged by the formed condensation.
- If the device fails to work properly, discontinue use immediately.



Attention
Before each use, examine the device visually for any defects.

Make sure that:

- All screws used for installing the device or parts of the device are tightly fastened and are not corroded.
- The safety devices are not damaged.
- There are no deformations on housings, fixings and installation points.
- The power cables are not damaged and do not show any material fatigue.



Attention
For professional use only
This device must be used only for the purposes it is designed for.

This device is designed to be used as a controller. Any incorrect use may lead to hazardous situations and result in injuries and material damage.

- This device is not suitable for households.
- This device does not contain user-serviceable parts. Unauthorized modifications to the device will render the warranty void. Such modifications may result in injuries and material damage.

**Attention****Do not expose the device to conditions that exceed the rated IP class conditions.**

This device is IP65 rated. IP (Ingress Protection) 65 class means that the device is dust-tight and protected against harmful effect of water jets.

Keep the connectors sealed with the rubber caps when the connectors are not in use.

2.2. Requirements for the User

This product may be used by ordinary persons. Maintenance may be carried out by ordinary persons. Installation and service shall be carried out only by instructed or skilled persons. Contact your Highlite International dealer for more information.

Instructed persons have been instructed and trained by a skilled person, or are supervised by a skilled person, for specific tasks and work activities associated with the installation, service and maintenance of this product, so that they can identify risks and take precautions to avoid them.

Skilled persons have training or experience, which enables them to recognize risks and avoid hazards associated with the installation, service and maintenance of this product.

Ordinary persons are all persons other than instructed persons and skilled persons. Ordinary persons include not only users of the product but also any other persons that may have access to the device or who may be in the vicinity of the device.

2.3. Personal Protective Equipment

During installation, deinstallation and rigging wear personal protective equipment in compliance with the national and site-specific regulations.

3. Description of the Device

The Showtec Controller for Octostrip FLEX is a dedicated IP65-rated controller that can control up to 8 units of the Showtec Single Strip for Octostrip FLEX. It can control the 1 m and 0,5 m versions. Having both lengths in one setup is not possible. The device can be controlled via DMX/RDM, Art-Net, sACN and in master/slave mode.

3.1. Front View

Figure 2

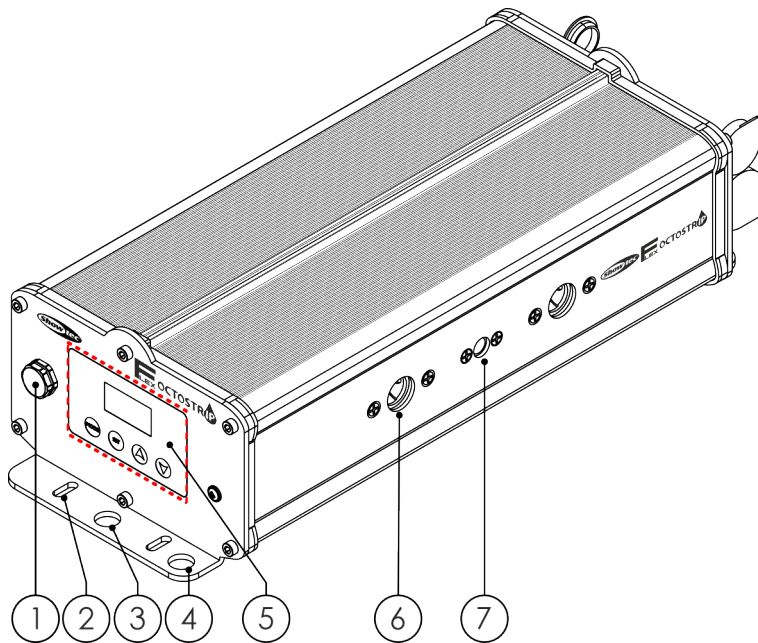

- 01) Protective valve
- 02) 4x Mounting holes
- 03) 2x Mounting holes, Ø 12,5 mm
- 04) Safety eye
- 05) Control panel: OLED display and touch buttons
- 06) 2x Mounting holes for a quick-lock bracket
- 07) Threaded insert M10

3.2. Back View

Figure 3

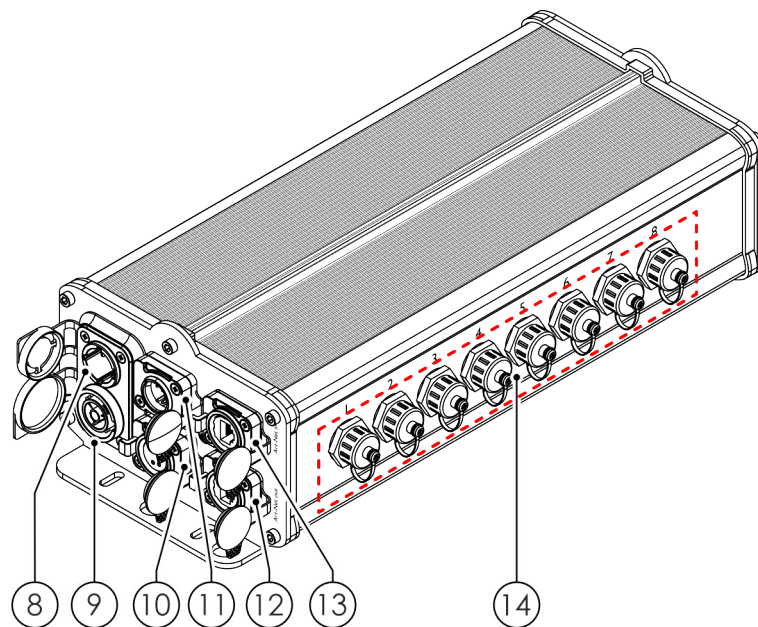

- 08) IP65-rated Seetronic power connector IN, 100-240 V
- 09) IP65-rated Seetronic power connector OUT, 100-240 V
- 10) IP65-rated 5-pin DMX signal connector OUT
- 11) IP65-rated 5-pin DMX signal connector IN
- 12) IP65-rated RJ45 connector OUT
- 13) IP65-rated RJ45 connector IN
- 14) 8x LED strip connectors OUT (data and power)

3.3. Product Specifications

Model:	Controller for Octostrip FLEX
--------	-------------------------------

Control and Programming:

Control mode	Art-Net / Auto / DMX / Manual / RDM / sACN
DMX channels	9 / 16 / 30 / 32 / 58 / 128 / 192 / 256 / 384
Protocols	Art-Net / DMX / sACN
Display	OLED

Dynamic Effects:

Dimmer	0–100 %
Strobe	0–20 Hz

Electrical Specifications and Connections:

Power supply	100–240 V AC 50/60 Hz
Power consumption	11,3 W
Power connector IN	Power Pro True
Power connector OUT	Power Pro True
DMX connector IN	XLR 5P
DMX connector OUT	XLR 5P
Data connector IN	etherCON
Data connector OUT	etherCON

Mechanical Specifications:

Height	103 mm
Width	171 mm
Depth	372 mm
Weight	3 kg
IP rating	IP65
Material	Aluminum
Housing	Aluminum
Color	Black

Product Properties:

Cooling	Convection
---------	------------

Rigging:

Mounting options	Clamp / Quick-Lock
------------------	--------------------

Thermal Specifications:

Maximum ambient temperature	45 °C
Minimum ambient temperature	-5 °C

Included Items:

Included cables	Power Pro True Cable
-----------------	----------------------

3.4. Optional Accessories

You can additionally purchase the following accessories:

- [30788](#) FLEX Cable – 2,5 m
- [30794](#) FLEX Cable – 5 m
- [30789](#) FLEX Cable – 10 m

Contact your Highlite International dealer for more information.

3.5. Compatibility



Attention
Product compatibility

The Showtec Controller for Octostrip FLEX is designed to be operated only with the Showtec Single Strip for Octostrip FLEX. It can control the 1 m and 0,5 m versions. You can connect up to 8 units of the Showtec Single Strip for Octostrip FLEX to the device.

Note:

You cannot use both lengths in one setup.

Compatible products:

- [42237](#) Single Strip for Octostrip FLEX – 1M
- [42242](#) Single Strip for Octostrip FLEX – 0,5M

Contact your Highlite International dealer for more information.

3.6. Dimensions

Figure 4

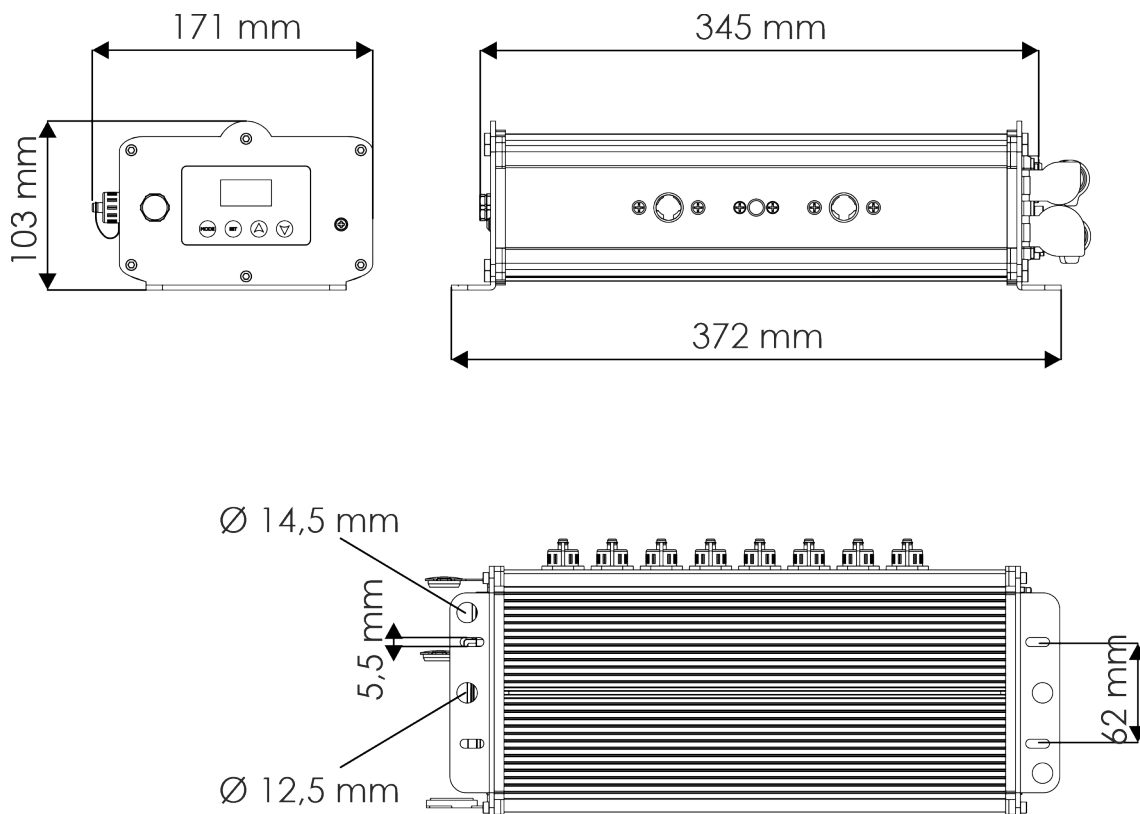

4. Installation

4.1. Safety Instructions for Installation

**WARNING**

Incorrect installation can cause serious injuries and damage of property.

If trussing systems are used, installation must be carried out only by instructed or skilled persons.

Follow all applicable European, national and local safety regulations concerning rigging and trussing.

4.2. Personal Protective Equipment

During installation, deinstallation and rigging wear personal protective equipment in compliance with the national and site-specific regulations.

4.3. Installation Site Requirements

- The device can be used indoors and outdoors.
- The device must be installed away from heating sources and direct sunlight.
- The ambient temperature must be in the range -5 and 45 °C.

4.4. Rigging



CAUTION

Restrict the access under the work area during rigging/derigging.

You can position the controller on a flat surface or mount it to a rigging structure (see [4.4.1. Installation with a Clamp](#)) or to a flat surface (see [4.4.2. Installation on a Flat Surface](#)).

Make sure that all loads are within the pre-determined limits of the supporting structure.

4.4.1. Installation with a Clamp

You can mount the controller to a rigging structure in 2 ways:

- With a quick-lock bracket and a clamp, using the 2 **mounting holes for a quick-lock bracket (06)**
- With a clamp, using the **threaded insert M10 (07)** or the 2 **mounting holes, Ø 12,5 mm (03)**

To mount the controller to a rigging structure:

- 01) Fasten the quick-lock bracket on the **mounting holes for a quick-lock bracket (06)**. Do not do step 1 if you install the device without a quick-lock bracket.
- 02) Attach the clamp to the quick-lock bracket or to the **threaded insert M10 (07)**. Make sure that you use a clamp suitable for attaching the controller to a truss.
- 03) Attach the controller to the supporting structure. Make sure that the controller cannot move freely.
- 04) Secure the controller with a secondary suspension, for example a safety cable. Make sure that the secondary suspension can hold 10 times the weight of the controller. If possible, the secondary suspension should be attached to a supporting structure independent of the primary suspension. Put the safety cable through the **safety eye (04)**.

Figure 5

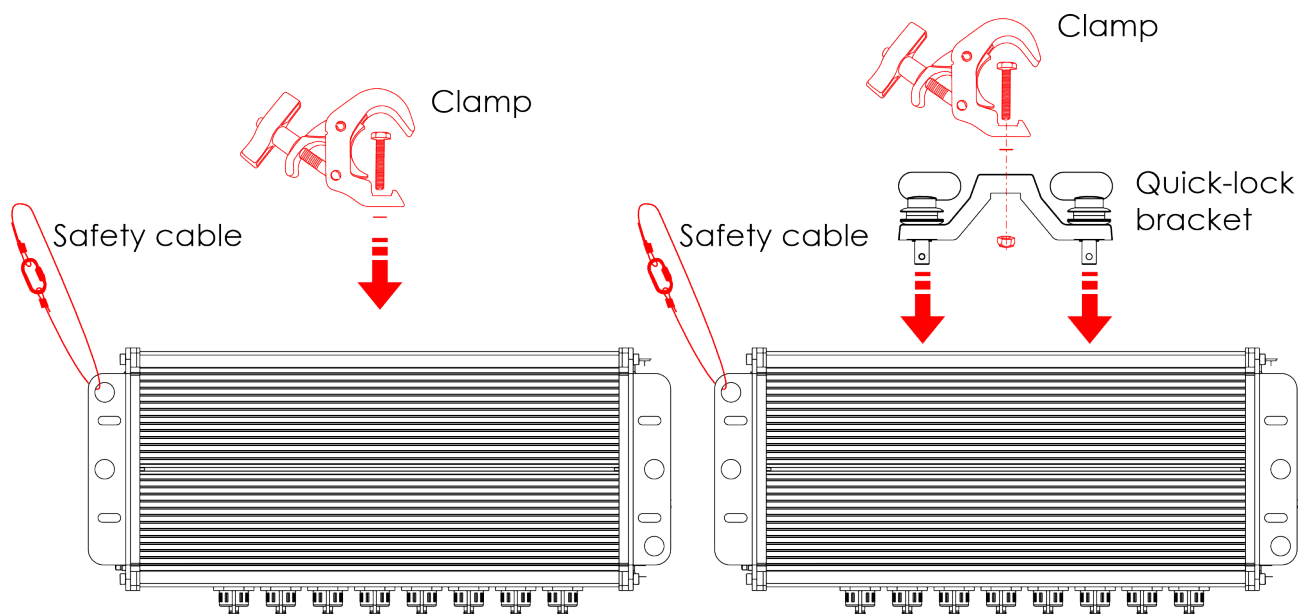

4.4.2. Installation on a Flat Surface

You can mount the controller on a flat surface, using the 4 **mounting holes (02)**.

You need the following:

- a drill
- a drill bit (for wood or concrete), 6–7 mm long
- 4 anchors (if applicable)
- 4 screws

Notes:

- Make sure that the drilling location for the mounting holes is free of obstructions such as pipes, ducts, or wires.
- Do not drill into mortar joints. Screws installed in mortar joints cannot safely support the weight of the device.

To mount the controller on a flat surface follow the steps below:

- 01) Hold the controller against the flat surface and mark the position of the 4 **mounting holes (02)** on the flat surface.
- 02) Drill holes at the 4 marked locations.
- 03) Insert anchors into the drilled holes, if applicable.
- 04) Insert and tighten the 4 screws through the 4 **mounting holes (02)** into the 4 drilled holes to fasten the controller to the flat surface.

Figure 6

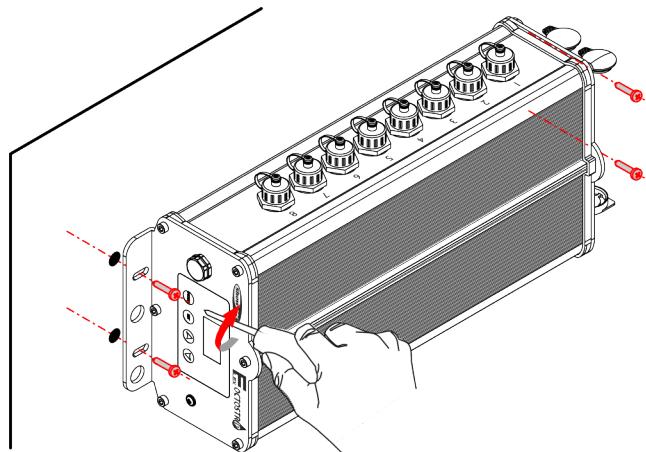

4.5. Connecting LED Strips to the Controller

The Showtec Controller for Octostrip FLEX is designed to be operated only with the Showtec Single Strip for Octostrip FLEX. It can control the 1 m and 0,5 m versions. You can connect up to 8 units of the Showtec Single Strip for Octostrip FLEX (see [3.5. Compatibility](#) on page 11) to the device.

Note:

You cannot use both lengths in one setup.

To connect LED strips to the controller, follow the steps below:

- 01) Connect the fixed cable with connector IN of the 1st LED strip to the 1st **LED strip connector OUT (14)** on the controller. To extend the length, you can use one of the extension cables available for purchase (see [3.4. Optional Accessories](#) on page 11). Contact your Highlite International dealer for more information.
- 02) Repeat step 1 to connect all LED strips to the controller.
- 03) Select the length of the connected LED strips in the Led Mode submenu (see [6.6.7.2. Led Mode](#) on page 31).

Figure 7

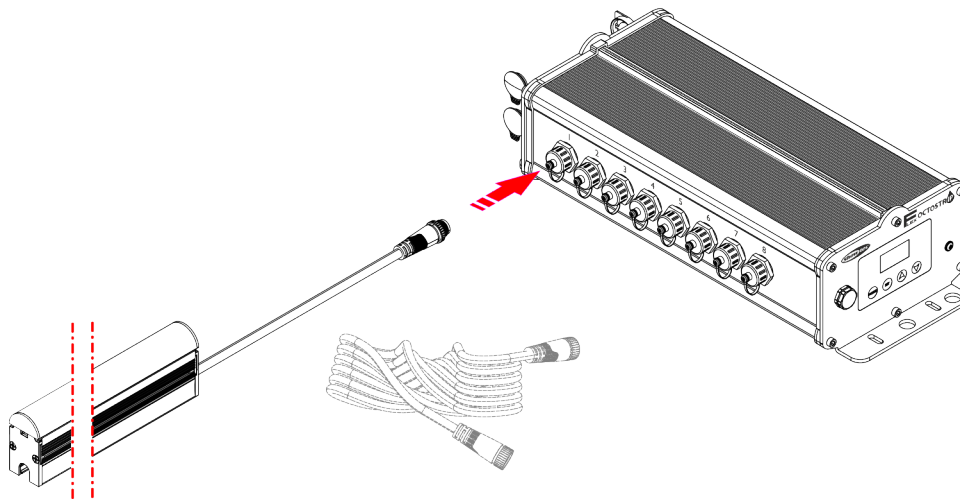

Note:

Keep the **LED strip connectors OUT (14)** sealed with the plastic caps when the connectors are not in use.

4.6. Connecting to Power Supply



DANGER
Electric shock caused by short-circuit

The device accepts AC mains power at 100–240 V and 50/60 Hz. Do not supply power at any other voltage or frequency to the device.

This device falls under IEC protection class I. Make sure that the device is always electrically connected to the ground (earth).

Before connecting the device to the socket-outlet:

- Make sure that the power supply matches the input voltage specified on the information label on the device.
- Make sure that the socket-outlet has a ground (earth) connection.

Connect the device to the socket-outlet with the power plug. Do not connect the device to a dimmer circuit, as this may damage the device.

This device is IP65 rated.

- Do not expose the device to conditions that exceed the rated IP class conditions.
- Keep the connectors sealed with the rubber caps when the connectors are not in use.
- Do not connect the cables from above the connectors, if the device is installed outdoors. Make a 'drip loop' in the cable so that rain water cannot enter the device.
- Make sure that the cable run is not too heavy. A heavy cable run can cause damage to the connectors. If the connectors are damaged, their ingress protection (IP) can deteriorate.

4.7. Power Linking of Multiple Devices

This device supports power linking. Power can be relayed to another device via the power OUT connector. Note that the input and the output connectors have different designs: one type cannot be connected to the other.

Power linking of multiple devices must be carried out only by instructed or skilled persons.



WARNING

Incorrect power linking may lead to overload of the electrical circuit and result in serious injuries and damage of property.

To prevent overload of the electrical circuit, when power linking multiple devices:

- Use cables with sufficient current-carrying capacity. The power cable supplied with the device is not suitable for power linking of multiple devices.
- Make sure that the total current draw of the device and all connected devices does not exceed the rated capacity of the power cables and the circuit breaker.
- Do not link more devices on one power link than the maximum recommended number.

The maximum recommended number of devices depends on the total load of all connected devices.

The total load shall not exceed:

- at 120 V: 1800 W
- at 230 V: 3500 W

5. Setup

5.1. Warnings and Precautions



DANGER
Electric shock caused by short-circuit

This device is IP65 rated.

- Do not expose the device to conditions that exceed the rated IP class conditions.
- Keep the connectors sealed with the rubber caps when the connectors are not in use.
- Do not connect the cables from above the connectors, if the device is installed outdoors. Make a 'drip loop' in the cable so that rain water cannot enter the device.
- Make sure that the cable run is not too heavy. A heavy cable run can cause damage to the connectors. If the connectors are damaged, their ingress protection (IP) can deteriorate.



Attention
Connect all data cables before supplying power.
Disconnect power supply before connecting or disconnecting data cables.

5.2. Stand-alone Setup

When the Controller for Octostrip FLEX is not connected to a DMX controller or to other devices, it functions as a stand-alone device. It can be operated manually via the control panel or in auto mode.

For more information refer to Control Modes (see [6.2. Control Modes](#) on page 23).

5.3. DMX Connection

5.3.1. DMX-512 Protocol

You need a DMX serial data link to run light shows of one or more devices using a DMX-512 controller.

The Controller for Octostrip FLEX has 5-pin DMX signal IN and OUT connectors.

The pin assignment is as follows: pin 1 (ground), pin 2 (-), pin 3 (+), pin 4 (N/C), pin 5 (N/C).

Devices on a serial data link must be daisy-chained in a single line. The number of devices that you can control on one data link is limited by the combined number of the DMX channels of the connected devices and the 512 channels available in one DMX universe.

To comply with the TIA-485 standard, no more than 32 devices should be connected on one data link. In order to connect more than 32 devices on one data link, you must use a DMX optically isolated splitter/booster, otherwise this may result in deterioration of the DMX signal.

Note:

- Maximum recommended DMX data link distance: 300 m
- Maximum recommended number of devices on a DMX data link: 32 devices

5.3.2. DMX Cables

Shielded twisted-pair cables with 5-pin XLR connectors must be used for reliable DMX connection. You can purchase DMX cables directly from your Highlite International dealer or make your own cables.

If you use XLR audio cables for DMX data transmission, this may lead to signal degradation and unreliable operation of the DMX network.

When you make your own DMX cables, make sure that you connect the pins and wires correctly as shown in the figure below.

Figure 8

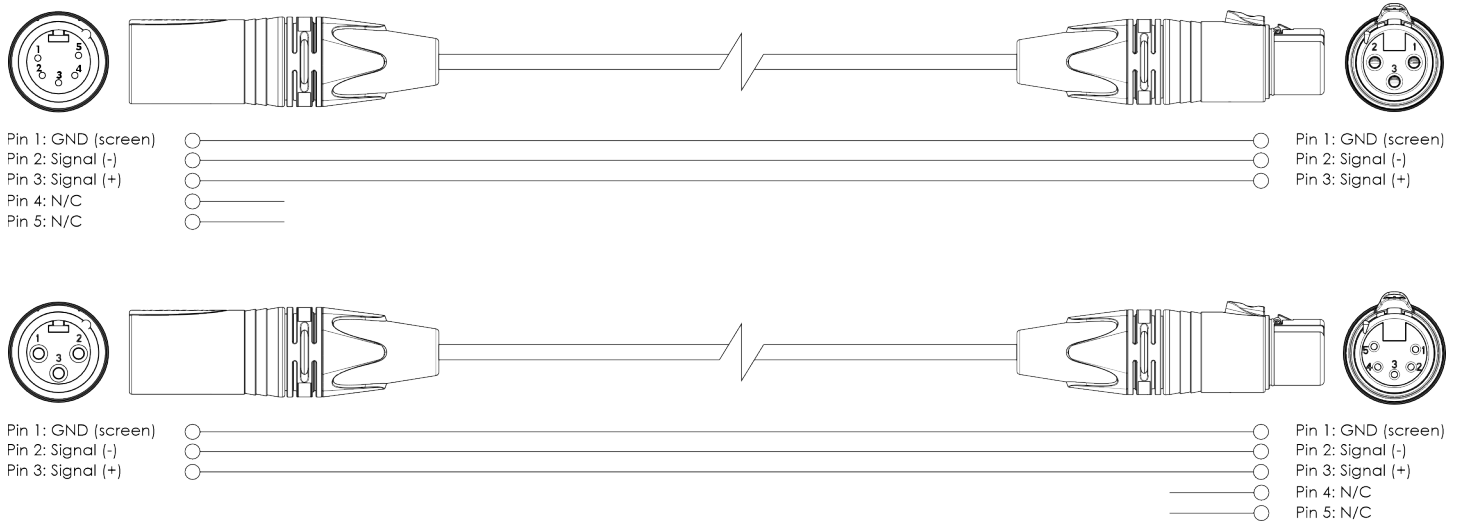

5.3.3. Master/Slave Setup

The Controller for Octostrip FLEX supports master/slave control mode. To connect multiple devices in a master/slave setup, follow the steps below:

- 01) Connect the DMX OUT connector of the 1st device to the DMX IN connector of the 2nd device with a 5-pin DMX cable.
- 02) Repeat step 1 to connect all devices in a daisy-chain.
- 03) Connect a DMX terminator (120 Ω resistor) to the DMX OUT connector of the last device on the data link.
- 04) Set the 1st device on the data link as a master device (see [6.6.6. Slave](#) on page 30).
- 05) Set the other devices on the data link as slave devices (see [6.6.6. Slave](#) on page 30).

Figure 9

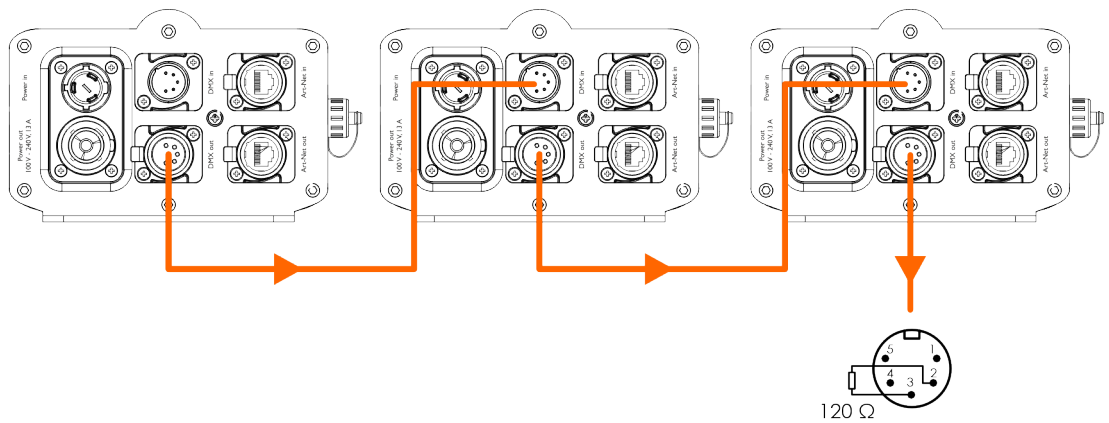

5.3.4. DMX Linking

To connect multiple devices on one DMX data link, follow the steps below:

- 01) Use a 5-pin DMX cable to connect the DMX OUT connector of the lighting controller to the DMX IN connector of the 1st device.
- 02) Connect the DMX OUT connector of the 1st device to the DMX IN connector of the 2nd device with a 5-pin DMX cable.
- 03) Repeat step 2 to connect all devices in a daisy-chain.
- 04) Connect a DMX terminator (120 Ω resistor) to the DMX OUT connector of the last device on the data link.

Figure 10

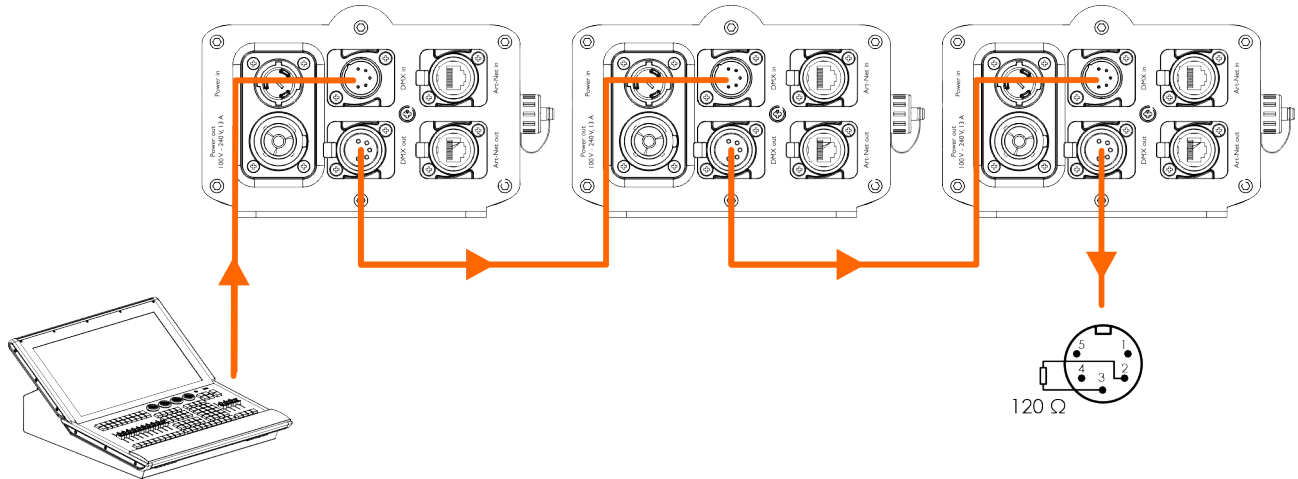

5.3.5. DMX Addressing

In a setup with multiple devices, make sure that you set the DMX starting address of each device correctly. The Controller for Octostrip FLEX has 7 personalities:

- when used with 1 m LED strips: 9 channels, 16 channels, 30 channels, 32 channels, 58 channels, 256 channels, and 384 channels
- when used with 0,5 m LED strips: 9 channels, 16 channels, 30 channels, 32 channels, 58 channels, 128 channels, and 192 channels

If you want to connect multiple devices on one data link and use them in 58-channel mode, for example, follow the steps below:

- 01) Set the starting address of the 1st device on the data link to 1 (001).
- 02) Set the starting address of the 2nd device on the data link to 59 (059), as $1 + 58 = 59$.
- 03) Set the starting address of the 3rd device on the data link to 117 (117), as $59 + 58 = 117$.
- 04) Continue assigning the starting addresses of the remaining devices by adding 58 to the previous number each time.

When addressing multiple devices on one data link, make sure that there are no overlapping channels. You cannot control devices individually if they have overlapping channels.

Note:

DMX connection is limited to 512 channels. For larger setups, connect the devices via Art-Net or sACN protocols (see [5.4. Ethernet Connection](#) on page 20).

5.4. Ethernet Connection

5.4.1. Art-Net/sACN Protocol

Art-Net is a protocol that uses TCP/IP to transfer a large amount of DMX-512 data over an Ethernet network. Art-Net 4 can support up to 32768 universes. Art-Net™ is designed by and copyright of Artistic Licence Holdings Ltd.

sACN (streaming Architecture for Control Networks), also known as ANSI E1.31, is a protocol developed by ESTA (Entertainment Services and Technology Association) for sending DMX-512 data over IP networks. It supports up to 63999 universes and uses multicasting.

5.4.2. Network Cables

Standard twisted-pair Ethernet cables (CAT-5E/CAT-6) can be used to connect the device to a computer or to a lighting controller that supports Art-Net or sACN.

If you make your own network cables, make sure that you connect the pins and wires correctly. Use RJ45 (8P8C) connectors and patch the cables according to the T568B color standard.

Figure 11

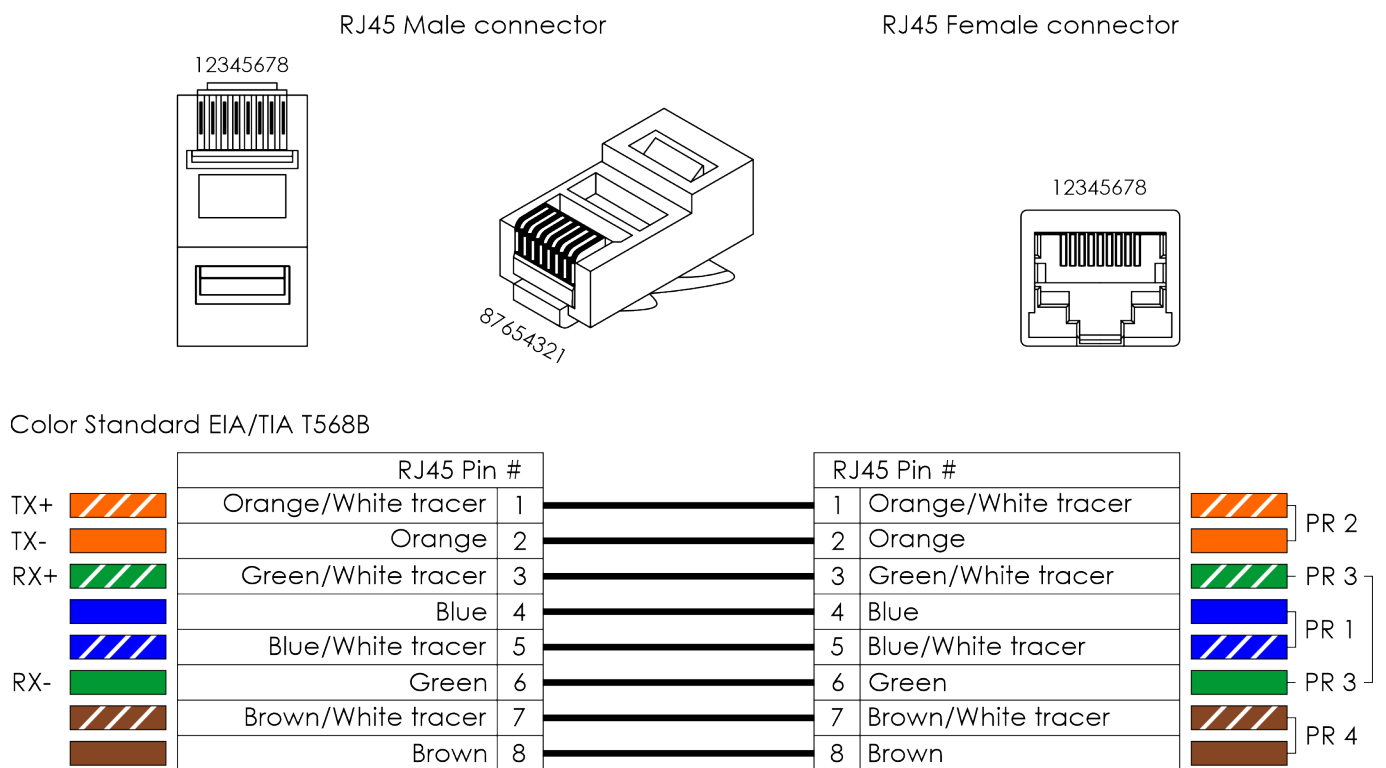

5.4.3. Art-Net/sACN Linking

To connect multiple devices on one Art-Net/sACN data link, follow the steps below:

- 01) Use a CAT-5E/CAT-6 cable to connect the RJ45 connector of the computer/lighting controller to one of the RJ45 connectors of the 1st device.
- 02) Connect the 2nd RJ45 connector of the 1st device to the 1st RJ45 connector of the 2nd device with a CAT-5E/CAT-6 cable.
- 03) Repeat step 2 to connect all devices in a daisy-chain.

Figure 12

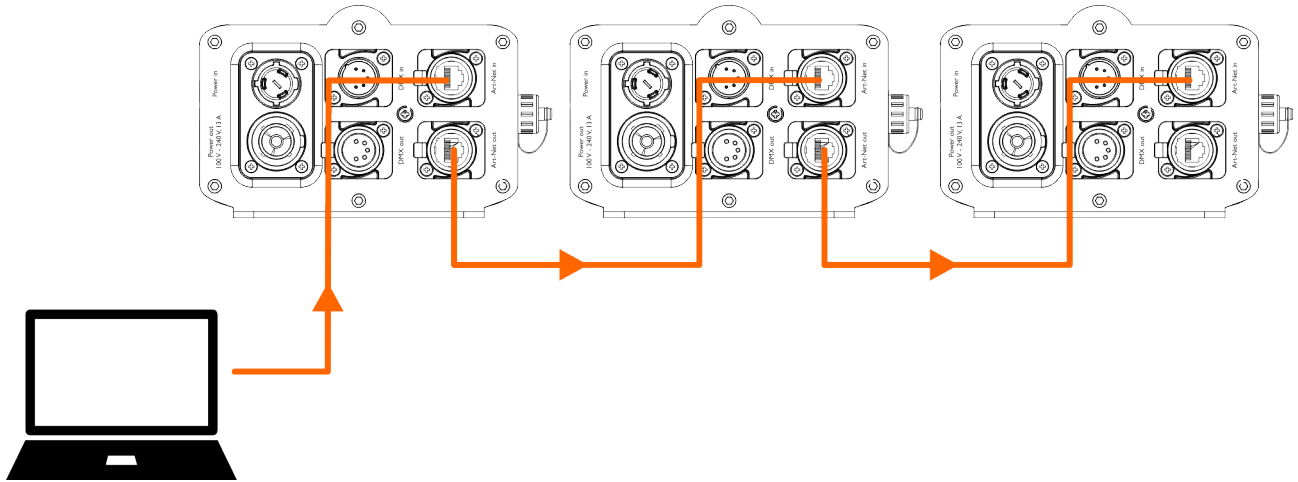

5.4.4. Art-Net Settings

To operate the device using Art-Net protocol:

- 01) Configure the network address of your computer/lighting controller in the correct range (IP 2.x.x.x, 10.x.x.x or 192.168.x.x and Subnet 255.0.0.0). You can configure the IP address and Subnet mask of the device Network Configuration menu (see [6.6.2. NetWork Configuration](#) on page 28). Make sure that all devices in the network have unique IP addresses.
- 02) Enable Art-Net Protocol in the ArtNet Enable submenu (see [6.6.2. NetWork Configuration](#) on page 28).
- 03) Set the universe in the ArtNet Universe submenu (see [6.6.2. NetWork Configuration](#) on page 28). For more information refer to Universe Numbering (see [5.4.6. Universe Numbering](#) on page 22).

5.4.5. sACN Settings

To operate the device using sACN protocol:

- 01) Set the IP address of your computer/lighting controller. sACN does not have restrictions on the IP address.
- 02) Enable sACN protocol in the sACN Enable submenu (see [6.6.2. NetWork Configuration](#) on page 28).
- 03) Set the universe in the sACN Universe submenu (see [6.6.2. NetWork Configuration](#) on page 28). For more information refer to Universe Numbering (see [5.4.6. Universe Numbering](#) on page 22).

5.4.6. Universe Numbering

If you want to connect 9 or more devices on one data link and use them in 58-channel mode, you need to address the devices on different universes.

- 01) Set the DMX starting address of the first 8 devices (see [5.3.5. DMX Addressing](#) on page 19).
- 02) Set the universe number of the 6th device to 001 and the DMX starting address to 001.
- 03) Continue addressing the devices, each time increasing the universe number, after you reach the limit of 512 channels in one universe.

There are 512 channels (1–512) in one universe. 16 consecutive universes (0–15) make up one sub-net. 16 sub-nets (0–15) make up one net. There are 128 nets (0–127) in total.

Note:

- In Art-Net, universes are called Port Address and number from 0 to 32767. There are 32768 unique numbers.
- In sACN, universes number from 1 to 63999.

15-bit Port Address	Net (0–127)	Sub-net (0–15)	Universe (0–15)
0	0	0	0
1	0	0	1
2	0	0	2
...
15	0	0	15
16	0	1	0
17	0	1	1
...
31	0	1	15
32	0	2	0
33	0	2	1
...
255	0	15	15
256	1	0	0
257	1	0	1
...
32766	127	15	14
32767	127	15	15

When addressing multiple devices on one data link, make sure that there are no overlapping channels. You cannot control devices individually if they have overlapping channels.

Note:

If you use an Art-Net controller that supports Art-Net I or Art-Net II, you need to set the Art-Net net to 0. The net number is available in Art-Net 3 and higher versions of the Art-Net protocol.

6. Operation

6.1. Safety Instructions for Operation



Attention

This device must be used only for the purposes it is designed for.

This device is intended for professional use as a controller. It can be installed indoors and outdoors. This device is not suitable for households and for general lighting.

Any other use, not mentioned under intended use, is regarded as non-intended and incorrect use.



Attention

Power supply

Before connecting the device to the power supply, make sure that the current, voltage and frequency match the input voltage, current and frequency specified on the information label on the device.

6.2. Control Modes

The Controller for Octostrip FLEX supports the following control modes:

- Stand-alone: Auto operation mode, built-in programs, manual operation
- Master/Slave: Auto operation mode, built-in programs, manual operation
- DMX-512/Art-Net/sACN:
 - when used with 1 m LED strips: 9 channels, 16 channels, 30 channels, 32 channels, 58 channels, 256 channels, and 384 channels
 - when used with 0,5 m LED strips: 9 channels, 16 channels, 30 channels, 32 channels, 58 channels, 128 channels, and 192 channels

For more information about how to connect the devices, refer to Setup (see [5. Setup](#) on page 17).

To operate the device manually as a stand-alone device or in a master/slave setup:

Adjust the intensity of the LED colors in the Manual Mode menu (see [6.6.3. Manual](#) on page 29).

To run the built-in program or to select one of the custom patterns in auto operation mode without a DMX controller:

Select the control mode of the device in the main menu.

- If you select Auto (see [6.6.4. Auto](#) on page 29), the device will run the built-in program.
- If you select Program (see [6.6.5. Program](#) on page 30), the device will run the respective program.

To operate the device with a DMX controller:

- 01) Set the DMX starting address (see [5.3.5. DMX Addressing](#) on page 19) of the device in the DMX Address submenu (see [6.6.1.1. Address](#) on page 27).
- 02) Select the length of the connected LED strips in the Led Mode submenu (see [6.6.7.2. Led Mode](#) on page 31).
- 03) Select the DMX personality in the DMX Channels submenu (see [6.6.1.2. Channels](#) on page 27). Refer to DMX Channels for a complete overview of all DMX personalities.

6.3. Control Panel

Figure 13

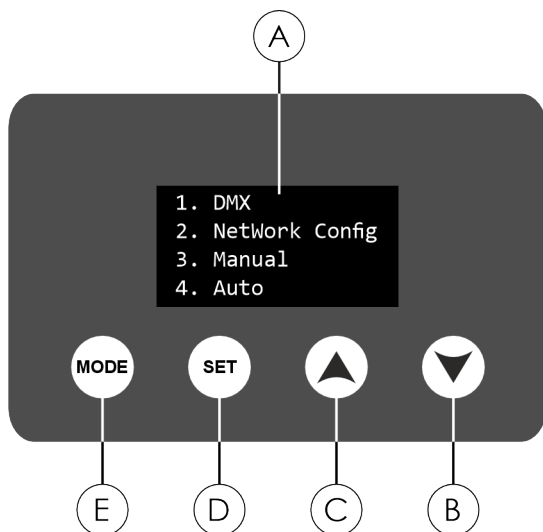

- A) OLED display
- B) DOWN touch button
- C) UP touch button
- D) SET touch button
- E) MODE touch button

- Use the **MODE** button to exit the current submenu and to return to the Main Menu.
- Use the **UP/DOWN** buttons to navigate through the menus or to increase/decrease numeric values.
- Use the **SET** button to open the selected menu, to confirm the setting or to confirm the currently selected value.

6.4. Start-up

After the device is connected to the power supply, the device performs a connectivity check. During the check, the display shows the firmware version, the temperature and the humidity percentage of the controller (MC), the status of the network connection, and that a connectivity check is ongoing. After the connectivity check is completed, the display shows information about which ports are connected to LED strips. Ports that are not connected, show X:

```
Version:1.9
MC:27°C 45%
network:ok
Connect Checking
```

```
Version:1.9
MC:27°C 45%
network:ok
1-2-3-4-5-6-X-X
```

After the connectivity check is completed, the device is ready to use. The display shows the start screen. The start screen provides information about the operation mode of the device, the highest temperature of the LEDs of the connected LED strips (L), and the temperature and the humidity percentage of the mainboard (P). If the temperature cannot be read, the display shows X:

```
Manual 
Color All
L:X°C P:26°C 47%
```

Note:

If the display is locked, press the **MODE** and **SET** buttons for 3 s at the same time to unlock the display. When the display lock is on, there is a lock symbol at the top right corner of the display.

6.5. Menu Overview

Level 1	Level 2	Level 3	Level 4	Level 5
DMX (see 6.6.1. DMX on page 27)	Address	001–512		
	Channels	009		
		016		
		030		
		032		
		058		
		256 or 128 384 or 192		
NetWork Config (see 6.6.2. NetWork Configuration on page 28)	Local IP	(Set the IP address)		
	Subnet Mask	255.255.255.0		
		255.255.0.0 255.0.0.0		
	ArtNet Enable	On		
		Off		
	ArtNet Uni	Net	000–127	
		Sub Port	00–15 00–15	
sACN Enable	On Off			
sACN Universe	00001–63999			
Mac Address	(Enter password: 6468)	(Set Mac Address)		
Manual (see 6.6.3. Manual on page 29)	Color All	All Red	000–255	
		All Green	000–255	
		All Blue	000–255	
		All White	000–255	
	Color Pixel	strip 1		
		strip 2		
		strip 3	Red X	000–255
		strip 4	Green X	000–255
		strip 5	Blue X	000–255
		strip 6	White X	000–255
	strip 7			
	strip 8			
Auto (see 6.6.4. Auto on page 29)	Yes			
	No			
Program (see 6.6.5. Program on page 30)	Mode	01–21		
	Color (only mode 1)	01–40		
	Speed (only mode 2–21)	001–100		
	Strobe	00–99		
Slave (see 6.6.6. Slave on page 30)	Yes			
	No			
Setting (see 6.6.7. Settings on page 30)	Patch	Default		
		Output 1	Strip 1	
		Output 2	Strip 2	
		Output 3	Strip 3	

Level 1	Level 2	Level 3	Level 4	Level 5
		Output 4	Strip 4	
		Output 5	Strip 5	
		Output 6	Strip 6	
		Output 7	Strip 7	
		Output 8	Strip 8	
	Led Mode	1.0M		
		0.5M		
	Curves Select	Linear		
		Square Law		
		Inv Square Law		
		S-Type		
	Dimmer Speed	Fast		
		Smooth		
	Display	Normal		
		Inverted		
	DMX Fail	Off		
		Hold		
		Manual		
		Program		
	Backlight Time	5s		
		10s		
		20s		
		30s		
		On		
	Lock	On		
		Off		
	Key Backlight	On		
		Off		
	Factory	Yes		
		No		
Information (see 6.6.8. Information on page 33)				

6.6. Main Menu Options

The main menu has the following options:

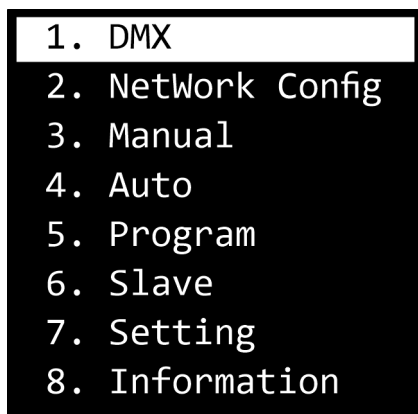

- 1. DMX
- 2. NetWork Configuration
- 3. Manual
- 4. Auto
- 5. Program
- 6. Slave
- 7. Setting
- 8. Information

- 01) Press the **UP/DOWN** buttons to navigate through the menu.
- 02) Press the **SET** button to open submenus.

6.6.1. DMX

In this menu you can configure the DMX settings of the device.

- 01) Press the **UP/DOWN** buttons to select one of the 2 options:



- Address (see [6.6.1.1. Address](#))
- Channels (see [6.6.1.2. Channels](#))

- 02) Press the **SET** button to confirm the selection.

6.6.1.1. Address

In this submenu you can set the DMX starting address of the device (see [5.3.5. DMX Addressing](#) on page 19).

- 01) Press the **UP/DOWN** buttons to select the DMX starting address. The selection range is 001–512.
- 02) Press the **SET** button to confirm the selection.

6.6.1.2. Channels

In this submenu you can select the DMX channel mode. For more information refer to DMX Channels (see [6.7. DMX Channels](#) on page 34).

- 01) Press the **UP/DOWN** buttons to select a DMX channel mode. There are 7 options:

- 009: 9 channels
- 016: 16 channels
- 030: 30 channels
- 032: 32 channels
- 058: 58 channels
- 256 / 128: 256 or 128 channels (see [6.6.7.2. Led Mode](#) on page 31)
- 384 / 192: 384 or 192 channels (see [6.6.7.2. Led Mode](#) on page 31)

- 02) Press the **SET** button to confirm the selection.

6.6.2. NetWork Configuration

In this menu you can configure the network settings of the device.

01) Press the **UP/DOWN** buttons to select one of the 7 options:

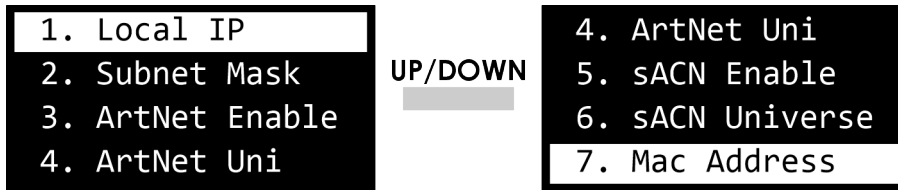

- Local IP (see [6.6.2.1. Local IP](#))
- Subnet Mask (see [6.6.2.2. Subnet Mask](#))
- ArtNet Enable: Enable ArtNet protocol (On/Off)
- ArtNet Uni (see [6.6.2.3. ArtNet Universe](#))
- sACN Enable: Enable sACN protocol (On/Off)
- sACN Universe: Set the sACN Universe (00001–63999)
- Mac Address: Change the MAC address of the device. This submenu requires a password. The password is 6468.

02) Press the **SET** button to confirm the selection.

03) Press the **UP/DOWN** buttons to change the values.

04) Press the **SET** button to confirm the setting.

6.6.2.1. Local IP

In this submenu you can manually configure the IP address of the device.

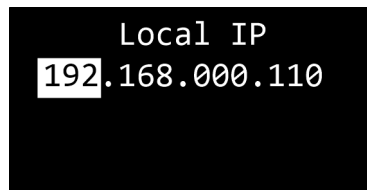

01) Press the **UP/DOWN** buttons to change the number of the 1st section of the IP address.

02) Press the **SET** button to confirm the change and select the next section. When a section is selected, the section is highlighted.

03) Repeat steps 1–2 to change the remaining 2 sections.

6.6.2.2. Subnet Mask

In this submenu you can set the subnet mask of the IP address.

01) Press the **UP/DOWN** buttons to select one of the 3 options:

- 255.255.255.0
- 255.255.0.0
- 255.0.0.0

02) Press the **SET** button to confirm the selection.

6.6.2.3. ArtNet Universe

In this submenu can you set the Art-Net universe of the device by adjusting the values for net, sub-net and port (see [5.4.6. Universe Numbering](#) on page 22).

01) Press the **UP/DOWN** buttons to select each of the 3 options:

- Net: Set the net. The input range is 000–127
- Sub: Set the sub-net. The input range is 00–15
- Port: Set the port. The input range is 00–15

02) Press the **SET** button to confirm the selection.

6.6.3. Manual

In this menu you can manually set the desired colors (red, green, blue, white) for all 8 LED strips together or for each LED strip individually.

01) Press the **UP/DOWN** buttons to select one of the 2 options:

- Color All (see [6.6.3.1. Color All](#))
- Color Pixel (see [6.6.3.2. Color Pixel](#))

02) Press the **SET** button to confirm the selection and open the submenu.

6.6.3.1. Color All

In this submenu you can adjust the intensity of each LED color for all 8 LED strips together.

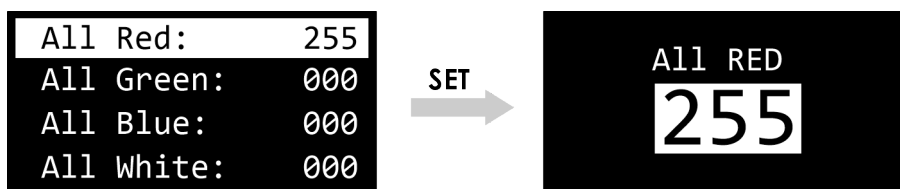

01) Press the **UP/DOWN** buttons to select one of the 4 options: Red, Green, Blue, White.

02) Press the **SET** button to open the submenu.

03) Press the **UP/DOWN** buttons to set the intensity of each LED color. The adjustment range is 0–255, from low to high intensity.

04) Press the **SET** button to confirm the value.

6.6.3.2. Color Pixel

In this submenu you can adjust the intensity of each LED color for each LED strip individually.

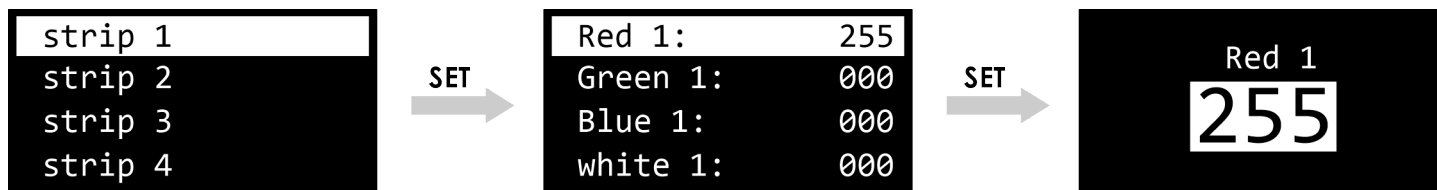

01) Press the **UP/DOWN** buttons to select one of the 8 LED strips (strip 1–8).

02) Press the **SET** button to confirm the selection.

03) Press the **UP/DOWN** buttons to select one of the 4 options: Red, Green, Blue, White.

04) Press the **SET** button to confirm the selection and open the submenu.

05) Press the **UP/DOWN** buttons to set the intensity of each LED color. The adjustment range is 0–255, from low to high intensity.

06) Press the **SET** button to confirm the value.

6.6.4. Auto

In this menu you can activate auto-run mode.

01) Press the **UP/DOWN** buttons to select one of the 2 options:

- Yes: Activate auto-run mode. The device runs the built-in programs (02–21) in a sequence with the speed and the strobe frequency selected in the Program submenu (see [6.6.5. Program](#) on page 30)
- No: Cancel the selection or stop the auto program

02) Press the **SET** button to confirm the selection.

6.6.5. Program

In this menu you can select a preset color or a built-in program.

Program	
Mode:	01
Color:	15
Strobe:	00

Mode 01

Program	
Mode:	02
Speed:	008
Strobe:	10

Mode 02-21

01) Press the **UP/DOWN** buttons to select one of the following options:

- Mode: Select static colors mode (Mode 01) or one of the 16 built-in chases (Mode 02-21)
- Color: Select one of the 40 preset colors (available for Mode 01 only). The selection range is 1-40
- Speed: Adjust the speed of the built-in program (available for Mode 02-21). The adjustment range is 1-100, from slow to fast
- Strobe: Add strobe effect (Mode 01-21). The adjustment range is 0-99, from off to high frequency

02) Press the **SET** button to confirm the selection.

6.6.6. Slave

In this menu you can set the device as a slave device in a master/slave setup.

01) Press the **UP/DOWN** buttons to select one of the 2 options:

- Yes: The device is set as a slave device
- No: The device is set as the master device

02) Press the **SET** button to confirm the selection.

6.6.7. Settings

In this menu you can adjust the settings of the device.



01) Press the **UP/DOWN** buttons to select one of the following options:

- Patch (see [6.6.7.1. Patch](#))
- Led Mode (see [6.6.7.2. Led Mode](#))
- Curves Select (see [6.6.7.3. Curves Select](#))
- Dimmer Speed: Set the dimmer speed (Fast/Smooth)
- Display (see [6.6.7.4. Display Invert](#))
- DMX Fail (see [6.6.7.5. DMX Fail](#))
- Backlight Time: Set whether the backlight of the display remains on (On) or turns off after the selected amount of time: 5 s, 10 s, 20 s, or 30 s
- Lock (see [6.6.7.6. Lock](#))
- Key Backlight: Turn the backlight of the 4 touch buttons (**MODE, SET, UP, DOWN**) on (On) or off (Off)
- Factory: Restore the default factory settings of the device (Yes/No)

02) Press the **SET** button to confirm the selection.

6.6.7.1. Patch

In this submenu you can patch LED strips to the 8 **LED strip connectors OUT (14)** on the controller.

01) Press the **UP/DOWN** buttons to select one of the options:

- Default: Select the default patch settings (Yes/No). The default patch settings are Output 1 = Strip 1, Output 2 = Strip 2, etc.
- Output 1–8 (see [6.6.7.1.1. Output 1–8](#))

02) Press the **SET** button to confirm the selection.

Note:

The numbering of the LED strips in the DMX chart corresponds to the default settings. If you patch the LED strips in a different way (see [6.6.7.1.1. Output 1–8](#)), controlling Strip 1 via DMX means controlling Output 1 of the controller and the respective LED strip patched to it.

6.6.7.1.1. Output 1–8

In this submenu you can manually patch the LED strips to the 8 **LED strip connectors OUT (14)** on the controller.

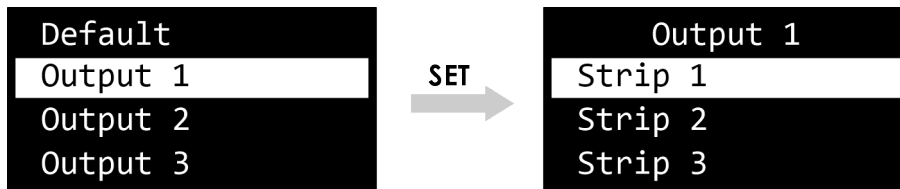

01) Press the **UP/DOWN** buttons to select one of the 8 outputs (Output 1–8).

02) Press the **SET** button to confirm the selection and open the submenu.

03) Press the **UP/DOWN** buttons to select one of the 8 LED strips (Strip 1–8).

04) Press the **SET** button to confirm the selection.

6.6.7.2. Led Mode

In this submenu you can select the length of the LED strips connected to the controller.

01) Press the **UP/DOWN** buttons to select one of the options:

- 1.0M: Select this option if you use the device with the 1 m LED strips (Product code: [42237](#))
- 0.5M: Select this option if you use the device with the 0,5 m LED strips (Product code: [42242](#))

02) Press the **SET** button to confirm the selection.

Note:

The 1 m LED strips have 8 sections and the 0,5 m LED strips have 4 sections.

6.6.7.3. Curves Select

In this submenu you can select the dimming curve.

01) Press the **UP/DOWN** buttons to select one of the 4 options:

- Linear
- Square Law
- Inv. Square law
- S-type

02) Press the **SET** button to confirm the selection.

Figure 14

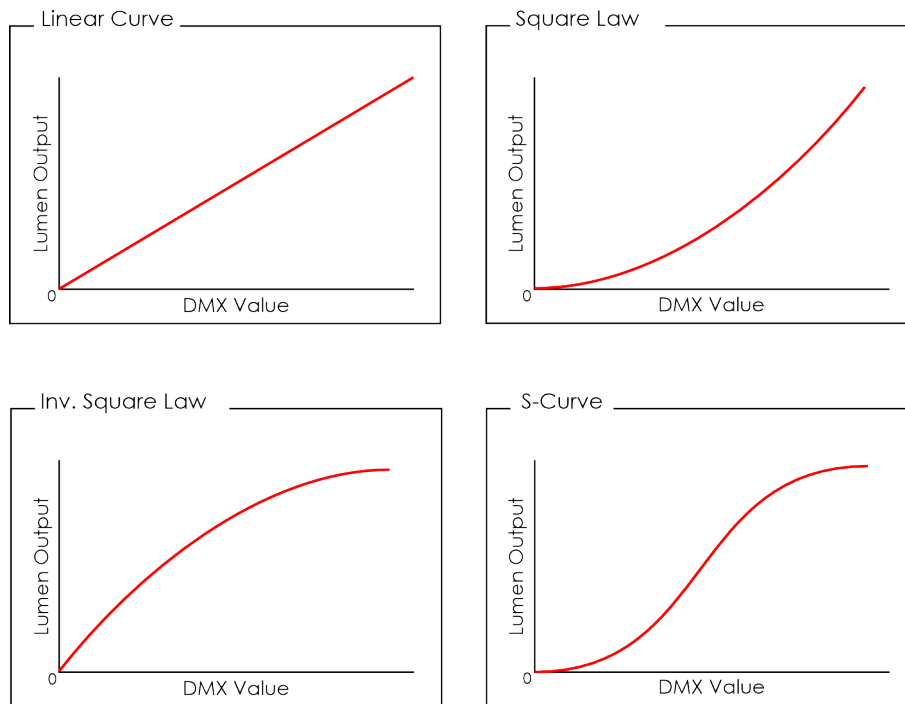

6.6.7.4. Display Invert

In this submenu you can set the orientation of the OLED display.

Press the **UP/DOWN** buttons to select one of the 2 options:

- Normal: Normal orientation of the OLED display
- Inverted: The OLED display is rotated at 180°

Note:

If the display is rotated at 180°, the function of the buttons on the control panel remains the same.

6.6.7.5. DMX Fail

In this submenu you can set the behavior of the device in case of a DMX failure.

01) Press the **UP/DOWN** buttons to select one of the 4 options:

- Off: The device blacks out the light output
- Hold: The device uses the last DMX signal correctly received
- Manual: The device uses the values selected in manual mode
- Program: The device uses the last used built-in program

02) Press the **SET** button to confirm the selection.

6.6.7.6. Lock

In this submenu you can activate the display lock.

01) Press the **UP/DOWN** buttons to toggle between On and Off:

- On: The display lock is on. The display is locked after 30 s of inactivity. After 5 s more the display turns off. To access the main menu, enter the password. The default password is pressing the **MODE** and **SET** buttons for 3 s at the same time. When the display lock is on, there is a lock symbol at the top right corner of the display on the start screen
- Off: The access to the main menu remains unlocked after the display turns off

02) Press the **SET** button to confirm the choice.

6.6.8. Information

In this menu you can view the parameters of the device.

Press the **UP/DOWN** buttons to navigate through the information screens:

```
V:1.9 MC:31°C44%
Life Time:00005h
UID:29B40F600024
1-2-X-4-5-6-7-8
```

- Firmware version
- MC: temperature and humidity of the mainboard of the controller
- Life time: operating hours of the LEDs
- UID: Unique Identification of the device
- Connection status: ports that are not connected show X

```
L1:X°C X°C X%
L2:X°C X°C X%
|
L8:X°C X°C X%
```

- L1-L8: temperature of the LEDs and the PCB of the connected LED strips, and humidity percentage in the housing of the LED strips

```
PowerFan 3630 rpm
DispFan 7950 rpm
```

- PowerFan: rotating speed of the fan of the controller
- DispFan: rotating speed of the fan of the controller display

6.7. DMX Channels

6.7.1. DMX Channels Overview

6.7.1.1. Strip and Section Control per DMX Personality

	9 CH	16 CH	30 CH	32 CH	58 CH	256/128 CH	384/192 CH
Strip	All	1-4 5-8	1-2 3-4 5-6 7-8	Individual strips	Individual strips	Individual strips	Individual strips
Sections	All	All	All	All	All	Individual per section	Individual per section

6.7.1.2. Functions per DMX Personality

	9 CH	16 CH	30 CH	32 CH	58 CH	256/128 CH	384/196 CH
Dimmer							
Strobe							
Red							
Green							
Blue							
White							
Preset colors							
Built-in programs							
Built-in programs speed							

6.7.2. 9 Channels

9 CH	Strips	Sections	Function	Value	Setting
1	All	All	Built-in programs	000-255	Refer to the channel overview (see 6.7.11. Built-in Programs Channel Overview on page 62)
2	All	All	Built-in programs speed	000-255	From slow to fast
3	All	All	Dimmer	000-255	From OFF to high intensity (0-100 %)
4	All	All	Strobe	000-004	No function
				005-255	From low to high frequency
5	All	All	Preset colors	000-255	Refer to the channel overview (see 6.7.12. Preset Colors Channel Overview on page 63)
6	All	All	Red	000-255	From OFF to high intensity (0-100 %)
7	All	All	Green	000-255	From OFF to high intensity (0-100 %)
8	All	All	Blue	000-255	From OFF to high intensity (0-100 %)
9	All	All	White	000-255	From OFF to high intensity (0-100 %)

6.7.3. 16 Channels

16 CH	Strips	Sections	Function	Value	Setting
1	All	All	Built-in programs	000–255	Refer to the channel overview (see 6.7.11. Built-in Programs Channel Overview on page 62)
2	All	All	Built-in programs speed	000–255	From slow to fast
3	Strip 1–4	All	Dimmer	000–255	From OFF to high intensity (0–100 %)
4	Strip 1–4	All	Strobe	000–004	No function
				005–255	From low to high frequency
5	Strip 1–4	All	Preset colors	000–255	Refer to the channel overview (see 6.7.12. Preset Colors Channel Overview on page 63)
6	Strip 1–4	All	Red	000–255	From OFF to high intensity (0–100 %)
7	Strip 1–4	All	Green	000–255	From OFF to high intensity (0–100 %)
8	Strip 1–4	All	Blue	000–255	From OFF to high intensity (0–100 %)
9	Strip 1–4	All	White	000–255	From OFF to high intensity (0–100 %)
10	Strip 5–8	All	Dimmer	000–255	From OFF to high intensity (0–100 %)
11	Strip 5–8	All	Strobe	000–004	No function
				005–255	From low to high frequency
12	Strip 5–8	All	Preset colors	000–255	Refer to the channel overview (see 6.7.12. Preset Colors Channel Overview on page 63)
13	Strip 5–8	All	Red	000–255	From OFF to high intensity (0–100 %)
14	Strip 5–8	All	Green	000–255	From OFF to high intensity (0–100 %)
15	Strip 5–8	All	Blue	000–255	From OFF to high intensity (0–100 %)
16	Strip 5–8	All	White	000–255	From OFF to high intensity (0–100 %)

6.7.4. 30 Channels

30 CH	Strips	Sections	Function	Value	Setting
1	All	All	Built-in programs	000–255	Refer to the channel overview
2	All	All	Built-in programs speed	000–255	From slow to fast
3	Strip 1–2	All	Dimmer	000–255	From OFF to high intensity (0–100 %)
4	Strip 1–2	All	Strobe	000–004	No function
				005–255	From low to high frequency
5	Strip 1–2	All	Preset colors	000–255	Refer to the channel overview
6	Strip 1–2	All	Red	000–255	From OFF to high intensity (0–100 %)
7	Strip 1–2	All	Green	000–255	From OFF to high intensity (0–100 %)
8	Strip 1–2	All	Blue	000–255	From OFF to high intensity (0–100 %)
9	Strip 1–2	All	White	000–255	From OFF to high intensity (0–100 %)
10	Strip 3–4	All	Dimmer	000–255	From OFF to high intensity (0–100 %)
11	Strip 3–4	All	Strobe	000–004	No function
				005–255	From low to high frequency
12	Strip 3–4	All	Preset colors	000–255	Refer to the channel overview
13	Strip 3–4	All	Red	000–255	From OFF to high intensity (0–100 %)
14	Strip 3–4	All	Green	000–255	From OFF to high intensity (0–100 %)
15	Strip 3–4	All	Blue	000–255	From OFF to high intensity (0–100 %)
16	Strip 3–4	All	White	000–255	From OFF to high intensity (0–100 %)
17	Strip 5–6	All	Dimmer	000–255	From OFF to high intensity (0–100 %)
18	Strip 5–6	All	Strobe	000–004	No function
				005–255	From low to high frequency

30 CH	Strips	Sections	Function	Value	Setting
19	Strip 5-6	All	Preset colors	000-255	Refer to the channel overview
20	Strip 5-6	All	Red	000-255	From OFF to high intensity (0-100 %)
21	Strip 5-6	All	Green	000-255	From OFF to high intensity (0-100 %)
22	Strip 5-6	All	Blue	000-255	From OFF to high intensity (0-100 %)
23	Strip 5-6	All	White	000-255	From OFF to high intensity (0-100 %)
24	Strip 7-8	All	Dimmer	000-255	From OFF to high intensity (0-100 %)
25	Strip 7-8	All	Strobe	000-004	No function
				005-255	From low to high frequency
26	Strip 7-8	All	Preset colors	000-255	Refer to the channel overview
27	Strip 7-8	All	Red	000-255	From OFF to high intensity (0-100 %)
28	Strip 7-8	All	Green	000-255	From OFF to high intensity (0-100 %)
29	Strip 7-8	All	Blue	000-255	From OFF to high intensity (0-100 %)
30	Strip 7-8	All	White	000-255	From OFF to high intensity (0-100 %)

6.7.5. 32 Channels

32 CH	Strips	Sections	Function	Value	Setting
1	Strip 1	All	Red	000-255	From OFF to high intensity (0-100 %)
2	Strip 1	All	Green	000-255	From OFF to high intensity (0-100 %)
3	Strip 1	All	Blue	000-255	From OFF to high intensity (0-100 %)
4	Strip 1	All	White	000-255	From OFF to high intensity (0-100 %)
5	Strip 2	All	Red	000-255	From OFF to high intensity (0-100 %)
6	Strip 2	All	Green	000-255	From OFF to high intensity (0-100 %)
7	Strip 2	All	Blue	000-255	From OFF to high intensity (0-100 %)
8	Strip 2	All	White	000-255	From OFF to high intensity (0-100 %)
9	Strip 3	All	Red	000-255	From OFF to high intensity (0-100 %)
10	Strip 3	All	Green	000-255	From OFF to high intensity (0-100 %)
11	Strip 3	All	Blue	000-255	From OFF to high intensity (0-100 %)
12	Strip 3	All	White	000-255	From OFF to high intensity (0-100 %)
13	Strip 4	All	Red	000-255	From OFF to high intensity (0-100 %)
14	Strip 4	All	Green	000-255	From OFF to high intensity (0-100 %)
15	Strip 4	All	Blue	000-255	From OFF to high intensity (0-100 %)
16	Strip 4	All	White	000-255	From OFF to high intensity (0-100 %)
17	Strip 5	All	Red	000-255	From OFF to high intensity (0-100 %)
18	Strip 5	All	Green	000-255	From OFF to high intensity (0-100 %)
19	Strip 5	All	Blue	000-255	From OFF to high intensity (0-100 %)
20	Strip 5	All	White	000-255	From OFF to high intensity (0-100 %)
21	Strip 6	All	Red	000-255	From OFF to high intensity (0-100 %)
22	Strip 6	All	Green	000-255	From OFF to high intensity (0-100 %)
23	Strip 6	All	Blue	000-255	From OFF to high intensity (0-100 %)
24	Strip 6	All	White	000-255	From OFF to high intensity (0-100 %)
25	Strip 7	All	Red	000-255	From OFF to high intensity (0-100 %)
26	Strip 7	All	Green	000-255	From OFF to high intensity (0-100 %)
27	Strip 7	All	Blue	000-255	From OFF to high intensity (0-100 %)
28	Strip 7	All	White	000-255	From OFF to high intensity (0-100 %)
29	Strip 8	All	Red	000-255	From OFF to high intensity (0-100 %)
30	Strip 8	All	Green	000-255	From OFF to high intensity (0-100 %)

32 CH	Strips	Sections	Function	Value	Setting
31	Strip 8	All	Blue	000–255	From OFF to high intensity (0–100 %)
32	Strip 8	All	White	000–255	From OFF to high intensity (0–100 %)

6.7.6. 58 Channels

58 CH	Strips	Sections	Function	Value	Setting
1	All	All	Built-in programs	000–255	Refer to the channel overview
2	All	All	Built-in programs speed	000–255	From slow to fast
3	Strip 1	All	Dimmer	000–255	From OFF to high intensity (0–100 %)
4	Strip 1	All	Strobe	000–004	No function
				005–255	From low to high frequency
5	Strip 1	All	Preset colors	000–255	Refer to the channel overview
6	Strip 1	All	Red	000–255	From OFF to high intensity (0–100 %)
7	Strip 1	All	Green	000–255	From OFF to high intensity (0–100 %)
8	Strip 1	All	Blue	000–255	From OFF to high intensity (0–100 %)
9	Strip 1	All	White	000–255	From OFF to high intensity (0–100 %)
10	Strip 2	All	Dimmer	000–255	From OFF to high intensity (0–100 %)
				000–004	No function
11	Strip 2	All	Strobe	005–255	From low to high frequency
				000–255	Refer to the channel overview
12	Strip 2	All	Preset colors	000–255	Refer to the channel overview
13	Strip 2	All	Red	000–255	From OFF to high intensity (0–100 %)
14	Strip 2	All	Green	000–255	From OFF to high intensity (0–100 %)
15	Strip 2	All	Blue	000–255	From OFF to high intensity (0–100 %)
16	Strip 2	All	White	000–255	From OFF to high intensity (0–100 %)
17	Strip 3	All	Dimmer	000–255	From OFF to high intensity (0–100 %)
				000–004	No function
18	Strip 3	All	Strobe	005–255	From low to high frequency
				000–255	Refer to the channel overview
19	Strip 3	All	Preset colors	000–255	Refer to the channel overview
20	Strip 3	All	Red	000–255	From OFF to high intensity (0–100 %)
21	Strip 3	All	Green	000–255	From OFF to high intensity (0–100 %)
22	Strip 3	All	Blue	000–255	From OFF to high intensity (0–100 %)
23	Strip 3	All	White	000–255	From OFF to high intensity (0–100 %)
24	Strip 4	All	Dimmer	000–255	From OFF to high intensity (0–100 %)
				000–004	No function
25	Strip 4	All	Strobe	005–255	From low to high frequency
				000–255	Refer to the channel overview
26	Strip 4	All	Preset colors	000–255	Refer to the channel overview
27	Strip 4	All	Red	000–255	From OFF to high intensity (0–100 %)
28	Strip 4	All	Green	000–255	From OFF to high intensity (0–100 %)
29	Strip 4	All	Blue	000–255	From OFF to high intensity (0–100 %)
30	Strip 4	All	White	000–255	From OFF to high intensity (0–100 %)
31	Strip 5	All	Dimmer	000–255	From OFF to high intensity (0–100 %)
				000–004	No function
32	Strip 5	All	Strobe	005–255	From low to high frequency
				000–255	Refer to the channel overview
33	Strip 5	All	Preset colors	000–255	Refer to the channel overview
34	Strip 5	All	Red	000–255	From OFF to high intensity (0–100 %)
35	Strip 5	All	Green	000–255	From OFF to high intensity (0–100 %)
36	Strip 5	All	Blue	000–255	From OFF to high intensity (0–100 %)

58 CH	Strips	Sections	Function	Value	Setting
37	Strip 5	All	White	000–255	From OFF to high intensity (0–100 %)
38	Strip 6	All	Dimmer	000–255	From OFF to high intensity (0–100 %)
39	Strip 6	All	Strobe	000–004	No function
				005–255	From low to high frequency
40	Strip 6	All	Preset colors	000–255	Refer to the channel overview
41	Strip 6	All	Red	000–255	From OFF to high intensity (0–100 %)
42	Strip 6	All	Green	000–255	From OFF to high intensity (0–100 %)
43	Strip 6	All	Blue	000–255	From OFF to high intensity (0–100 %)
44	Strip 6	All	White	000–255	From OFF to high intensity (0–100 %)
45	Strip 7	All	Dimmer	000–255	From OFF to high intensity (0–100 %)
46	Strip 7	All	Strobe	000–004	No function
				005–255	From low to high frequency
47	Strip 7	All	Preset colors	000–255	Refer to the channel overview
48	Strip 7	All	Red	000–255	From OFF to high intensity (0–100 %)
49	Strip 7	All	Green	000–255	From OFF to high intensity (0–100 %)
50	Strip 7	All	Blue	000–255	From OFF to high intensity (0–100 %)
51	Strip 7	All	White	000–255	From OFF to high intensity (0–100 %)
52	Strip 8	All	Dimmer	000–255	From OFF to high intensity (0–100 %)
53	Strip 8	All	Strobe	000–004	No function
				005–255	From low to high frequency
54	Strip 8	All	Preset colors	000–255	Refer to the channel overview
55	Strip 8	All	Red	000–255	From OFF to high intensity (0–100 %)
56	Strip 8	All	Green	000–255	From OFF to high intensity (0–100 %)
57	Strip 8	All	Blue	000–255	From OFF to high intensity (0–100 %)
58	Strip 8	All	White	000–255	From OFF to high intensity (0–100 %)

6.7.7. 256 Channels – 1 m LED Strips

Make sure that you choose 1.0M in the Led Mode submenu (see [6.6.7.2. Led Mode](#) on page 31) for setups with the 1 m version of the LED strips (Product code: [42237](#)).

The 1 m LED strip has 8 sections and the 0,5 m LED strip 4 sections.

Overview of the sections:

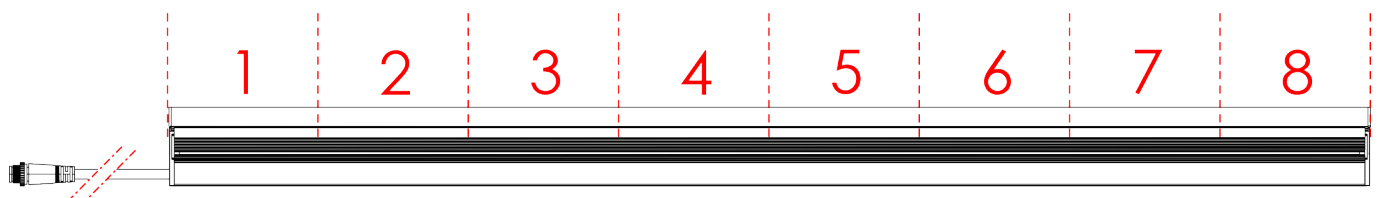

Figure 15

CH	Strips	Sections	Function	Value	Setting
1	Strip 1	Section 1	Red	000–255	From OFF to high intensity (0–100 %)
2			Green	000–255	From OFF to high intensity (0–100 %)
3			Blue	000–255	From OFF to high intensity (0–100 %)
4			White	000–255	From OFF to high intensity (0–100 %)
5	Strip 1	Section 2	Red	000–255	From OFF to high intensity (0–100 %)
6			Green	000–255	From OFF to high intensity (0–100 %)
7			Blue	000–255	From OFF to high intensity (0–100 %)

CH	Strips	Sections	Function	Value	Setting
8			White	000–255	From OFF to high intensity (0–100 %)
9	Strip 1	Section 3	Red	000–255	From OFF to high intensity (0–100 %)
10			Green	000–255	From OFF to high intensity (0–100 %)
11			Blue	000–255	From OFF to high intensity (0–100 %)
12			White	000–255	From OFF to high intensity (0–100 %)
13	Strip 1	Section 4	Red	000–255	From OFF to high intensity (0–100 %)
14			Green	000–255	From OFF to high intensity (0–100 %)
15			Blue	000–255	From OFF to high intensity (0–100 %)
16			White	000–255	From OFF to high intensity (0–100 %)
17	Strip 1	Section 5	Red	000–255	From OFF to high intensity (0–100 %)
18			Green	000–255	From OFF to high intensity (0–100 %)
19			Blue	000–255	From OFF to high intensity (0–100 %)
20			White	000–255	From OFF to high intensity (0–100 %)
21	Strip 1	Section 6	Red	000–255	From OFF to high intensity (0–100 %)
22			Green	000–255	From OFF to high intensity (0–100 %)
23			Blue	000–255	From OFF to high intensity (0–100 %)
24			White	000–255	From OFF to high intensity (0–100 %)
25	Strip 1	Section 7	Red	000–255	From OFF to high intensity (0–100 %)
26			Green	000–255	From OFF to high intensity (0–100 %)
27			Blue	000–255	From OFF to high intensity (0–100 %)
28			White	000–255	From OFF to high intensity (0–100 %)
29	Strip 1	Section 8	Red	000–255	From OFF to high intensity (0–100 %)
30			Green	000–255	From OFF to high intensity (0–100 %)
31			Blue	000–255	From OFF to high intensity (0–100 %)
32			White	000–255	From OFF to high intensity (0–100 %)
33	Strip 2	Section 1	Red	000–255	From OFF to high intensity (0–100 %)
34			Green	000–255	From OFF to high intensity (0–100 %)
35			Blue	000–255	From OFF to high intensity (0–100 %)
36			White	000–255	From OFF to high intensity (0–100 %)
37	Strip 2	Section 2	Red	000–255	From OFF to high intensity (0–100 %)
38			Green	000–255	From OFF to high intensity (0–100 %)
39			Blue	000–255	From OFF to high intensity (0–100 %)
40			White	000–255	From OFF to high intensity (0–100 %)
41	Strip 2	Section 3	Red	000–255	From OFF to high intensity (0–100 %)
42			Green	000–255	From OFF to high intensity (0–100 %)
43			Blue	000–255	From OFF to high intensity (0–100 %)
44			White	000–255	From OFF to high intensity (0–100 %)
45	Strip 2	Section 4	Red	000–255	From OFF to high intensity (0–100 %)
46			Green	000–255	From OFF to high intensity (0–100 %)
47			Blue	000–255	From OFF to high intensity (0–100 %)
48			White	000–255	From OFF to high intensity (0–100 %)
49	Strip 2	Section 5	Red	000–255	From OFF to high intensity (0–100 %)
50			Green	000–255	From OFF to high intensity (0–100 %)
51			Blue	000–255	From OFF to high intensity (0–100 %)
52			White	000–255	From OFF to high intensity (0–100 %)
53	Strip 2	Section 6	Red	000–255	From OFF to high intensity (0–100 %)
54			Green	000–255	From OFF to high intensity (0–100 %)

CH	Strips	Sections	Function	Value	Setting
55			Blue	000–255	From OFF to high intensity (0–100 %)
56			White	000–255	From OFF to high intensity (0–100 %)
57	Strip 2	Section 7	Red	000–255	From OFF to high intensity (0–100 %)
58			Green	000–255	From OFF to high intensity (0–100 %)
59			Blue	000–255	From OFF to high intensity (0–100 %)
60			White	000–255	From OFF to high intensity (0–100 %)
61	Strip 2	Section 8	Red	000–255	From OFF to high intensity (0–100 %)
62			Green	000–255	From OFF to high intensity (0–100 %)
63			Blue	000–255	From OFF to high intensity (0–100 %)
64			White	000–255	From OFF to high intensity (0–100 %)
65	Strip 3	Section 1	Red	000–255	From OFF to high intensity (0–100 %)
66			Green	000–255	From OFF to high intensity (0–100 %)
67			Blue	000–255	From OFF to high intensity (0–100 %)
68			White	000–255	From OFF to high intensity (0–100 %)
69	Strip 3	Section 2	Red	000–255	From OFF to high intensity (0–100 %)
70			Green	000–255	From OFF to high intensity (0–100 %)
71			Blue	000–255	From OFF to high intensity (0–100 %)
72			White	000–255	From OFF to high intensity (0–100 %)
73	Strip 3	Section 3	Red	000–255	From OFF to high intensity (0–100 %)
74			Green	000–255	From OFF to high intensity (0–100 %)
75			Blue	000–255	From OFF to high intensity (0–100 %)
76			White	000–255	From OFF to high intensity (0–100 %)
77	Strip 3	Section 4	Red	000–255	From OFF to high intensity (0–100 %)
78			Green	000–255	From OFF to high intensity (0–100 %)
79			Blue	000–255	From OFF to high intensity (0–100 %)
80			White	000–255	From OFF to high intensity (0–100 %)
81	Strip 3	Section 5	Red	000–255	From OFF to high intensity (0–100 %)
82			Green	000–255	From OFF to high intensity (0–100 %)
83			Blue	000–255	From OFF to high intensity (0–100 %)
84			White	000–255	From OFF to high intensity (0–100 %)
85	Strip 3	Section 6	Red	000–255	From OFF to high intensity (0–100 %)
86			Green	000–255	From OFF to high intensity (0–100 %)
87			Blue	000–255	From OFF to high intensity (0–100 %)
88			White	000–255	From OFF to high intensity (0–100 %)
89	Strip 3	Section 7	Red	000–255	From OFF to high intensity (0–100 %)
90			Green	000–255	From OFF to high intensity (0–100 %)
91			Blue	000–255	From OFF to high intensity (0–100 %)
92			White	000–255	From OFF to high intensity (0–100 %)
93	Strip 3	Section 8	Red	000–255	From OFF to high intensity (0–100 %)
94			Green	000–255	From OFF to high intensity (0–100 %)
95			Blue	000–255	From OFF to high intensity (0–100 %)
96			White	000–255	From OFF to high intensity (0–100 %)
97	Strip 4	Section 1	Red	000–255	From OFF to high intensity (0–100 %)
98			Green	000–255	From OFF to high intensity (0–100 %)
99			Blue	000–255	From OFF to high intensity (0–100 %)
100			White	000–255	From OFF to high intensity (0–100 %)
101	Strip 4	Section 2	Red	000–255	From OFF to high intensity (0–100 %)

CH	Strips	Sections	Function	Value	Setting
102			Green	000–255	From OFF to high intensity (0–100 %)
103			Blue	000–255	From OFF to high intensity (0–100 %)
104			White	000–255	From OFF to high intensity (0–100 %)
105	Strip 4	Section 3	Red	000–255	From OFF to high intensity (0–100 %)
106			Green	000–255	From OFF to high intensity (0–100 %)
107			Blue	000–255	From OFF to high intensity (0–100 %)
108			White	000–255	From OFF to high intensity (0–100 %)
109	Strip 4	Section 4	Red	000–255	From OFF to high intensity (0–100 %)
110			Green	000–255	From OFF to high intensity (0–100 %)
111			Blue	000–255	From OFF to high intensity (0–100 %)
112			White	000–255	From OFF to high intensity (0–100 %)
113	Strip 4	Section 5	Red	000–255	From OFF to high intensity (0–100 %)
114			Green	000–255	From OFF to high intensity (0–100 %)
115			Blue	000–255	From OFF to high intensity (0–100 %)
116			White	000–255	From OFF to high intensity (0–100 %)
117	Strip 4	Section 6	Red	000–255	From OFF to high intensity (0–100 %)
118			Green	000–255	From OFF to high intensity (0–100 %)
119			Blue	000–255	From OFF to high intensity (0–100 %)
120			White	000–255	From OFF to high intensity (0–100 %)
121	Strip 4	Section 7	Red	000–255	From OFF to high intensity (0–100 %)
122			Green	000–255	From OFF to high intensity (0–100 %)
123			Blue	000–255	From OFF to high intensity (0–100 %)
124			White	000–255	From OFF to high intensity (0–100 %)
125	Strip 4	Section 8	Red	000–255	From OFF to high intensity (0–100 %)
126			Green	000–255	From OFF to high intensity (0–100 %)
127			Blue	000–255	From OFF to high intensity (0–100 %)
128			White	000–255	From OFF to high intensity (0–100 %)
129	Strip 5	Section 1	Red	000–255	From OFF to high intensity (0–100 %)
130			Green	000–255	From OFF to high intensity (0–100 %)
131			Blue	000–255	From OFF to high intensity (0–100 %)
132			White	000–255	From OFF to high intensity (0–100 %)
133	Strip 5	Section 2	Red	000–255	From OFF to high intensity (0–100 %)
134			Green	000–255	From OFF to high intensity (0–100 %)
135			Blue	000–255	From OFF to high intensity (0–100 %)
136			White	000–255	From OFF to high intensity (0–100 %)
137	Strip 5	Section 3	Red	000–255	From OFF to high intensity (0–100 %)
138			Green	000–255	From OFF to high intensity (0–100 %)
139			Blue	000–255	From OFF to high intensity (0–100 %)
140			White	000–255	From OFF to high intensity (0–100 %)
141	Strip 5	Section 4	Red	000–255	From OFF to high intensity (0–100 %)
142			Green	000–255	From OFF to high intensity (0–100 %)
143			Blue	000–255	From OFF to high intensity (0–100 %)
144			White	000–255	From OFF to high intensity (0–100 %)
145	Strip 5	Section 5	Red	000–255	From OFF to high intensity (0–100 %)
146			Green	000–255	From OFF to high intensity (0–100 %)
147			Blue	000–255	From OFF to high intensity (0–100 %)
148			White	000–255	From OFF to high intensity (0–100 %)

CH	Strips	Sections	Function	Value	Setting
149	Strip 5	Section 6	Red	000–255	From OFF to high intensity (0–100 %)
150			Green	000–255	From OFF to high intensity (0–100 %)
151			Blue	000–255	From OFF to high intensity (0–100 %)
152			White	000–255	From OFF to high intensity (0–100 %)
153	Strip 5	Section 7	Red	000–255	From OFF to high intensity (0–100 %)
154			Green	000–255	From OFF to high intensity (0–100 %)
155			Blue	000–255	From OFF to high intensity (0–100 %)
156			White	000–255	From OFF to high intensity (0–100 %)
157	Strip 5	Section 8	Red	000–255	From OFF to high intensity (0–100 %)
158			Green	000–255	From OFF to high intensity (0–100 %)
159			Blue	000–255	From OFF to high intensity (0–100 %)
160			White	000–255	From OFF to high intensity (0–100 %)
161	Strip 6	Section 1	Red	000–255	From OFF to high intensity (0–100 %)
162			Green	000–255	From OFF to high intensity (0–100 %)
163			Blue	000–255	From OFF to high intensity (0–100 %)
164			White	000–255	From OFF to high intensity (0–100 %)
165	Strip 6	Section 2	Red	000–255	From OFF to high intensity (0–100 %)
166			Green	000–255	From OFF to high intensity (0–100 %)
167			Blue	000–255	From OFF to high intensity (0–100 %)
168			White	000–255	From OFF to high intensity (0–100 %)
169	Strip 6	Section 3	Red	000–255	From OFF to high intensity (0–100 %)
170			Green	000–255	From OFF to high intensity (0–100 %)
171			Blue	000–255	From OFF to high intensity (0–100 %)
172			White	000–255	From OFF to high intensity (0–100 %)
173	Strip 6	Section 4	Red	000–255	From OFF to high intensity (0–100 %)
174			Green	000–255	From OFF to high intensity (0–100 %)
175			Blue	000–255	From OFF to high intensity (0–100 %)
176			White	000–255	From OFF to high intensity (0–100 %)
177	Strip 6	Section 5	Red	000–255	From OFF to high intensity (0–100 %)
178			Green	000–255	From OFF to high intensity (0–100 %)
179			Blue	000–255	From OFF to high intensity (0–100 %)
180			White	000–255	From OFF to high intensity (0–100 %)
181	Strip 6	Section 6	Red	000–255	From OFF to high intensity (0–100 %)
182			Green	000–255	From OFF to high intensity (0–100 %)
183			Blue	000–255	From OFF to high intensity (0–100 %)
184			White	000–255	From OFF to high intensity (0–100 %)
185	Strip 6	Section 7	Red	000–255	From OFF to high intensity (0–100 %)
186			Green	000–255	From OFF to high intensity (0–100 %)
187			Blue	000–255	From OFF to high intensity (0–100 %)
188			White	000–255	From OFF to high intensity (0–100 %)
189	Strip 6	Section 8	Red	000–255	From OFF to high intensity (0–100 %)
190			Green	000–255	From OFF to high intensity (0–100 %)
191			Blue	000–255	From OFF to high intensity (0–100 %)
192			White	000–255	From OFF to high intensity (0–100 %)
193	Strip 7	Section 1	Red	000–255	From OFF to high intensity (0–100 %)
194			Green	000–255	From OFF to high intensity (0–100 %)
195			Blue	000–255	From OFF to high intensity (0–100 %)

CH	Strips	Sections	Function	Value	Setting
196			White	000–255	From OFF to high intensity (0–100 %)
197	Strip 7	Section 2	Red	000–255	From OFF to high intensity (0–100 %)
198			Green	000–255	From OFF to high intensity (0–100 %)
199			Blue	000–255	From OFF to high intensity (0–100 %)
200			White	000–255	From OFF to high intensity (0–100 %)
201	Strip 7	Section 3	Red	000–255	From OFF to high intensity (0–100 %)
202			Green	000–255	From OFF to high intensity (0–100 %)
203			Blue	000–255	From OFF to high intensity (0–100 %)
204			White	000–255	From OFF to high intensity (0–100 %)
205	Strip 7	Section 4	Red	000–255	From OFF to high intensity (0–100 %)
206			Green	000–255	From OFF to high intensity (0–100 %)
207			Blue	000–255	From OFF to high intensity (0–100 %)
208			White	000–255	From OFF to high intensity (0–100 %)
209	Strip 7	Section 5	Red	000–255	From OFF to high intensity (0–100 %)
210			Green	000–255	From OFF to high intensity (0–100 %)
211			Blue	000–255	From OFF to high intensity (0–100 %)
212			White	000–255	From OFF to high intensity (0–100 %)
213	Strip 7	Section 6	Red	000–255	From OFF to high intensity (0–100 %)
214			Green	000–255	From OFF to high intensity (0–100 %)
215			Blue	000–255	From OFF to high intensity (0–100 %)
216			White	000–255	From OFF to high intensity (0–100 %)
217	Strip 7	Section 7	Red	000–255	From OFF to high intensity (0–100 %)
218			Green	000–255	From OFF to high intensity (0–100 %)
219			Blue	000–255	From OFF to high intensity (0–100 %)
220			White	000–255	From OFF to high intensity (0–100 %)
221	Strip 7	Section 8	Red	000–255	From OFF to high intensity (0–100 %)
222			Green	000–255	From OFF to high intensity (0–100 %)
223			Blue	000–255	From OFF to high intensity (0–100 %)
224			White	000–255	From OFF to high intensity (0–100 %)
225	Strip 8	Section 1	Red	000–255	From OFF to high intensity (0–100 %)
226			Green	000–255	From OFF to high intensity (0–100 %)
227			Blue	000–255	From OFF to high intensity (0–100 %)
228			White	000–255	From OFF to high intensity (0–100 %)
229	Strip 8	Section 2	Red	000–255	From OFF to high intensity (0–100 %)
230			Green	000–255	From OFF to high intensity (0–100 %)
231			Blue	000–255	From OFF to high intensity (0–100 %)
232			White	000–255	From OFF to high intensity (0–100 %)
233	Strip 8	Section 3	Red	000–255	From OFF to high intensity (0–100 %)
234			Green	000–255	From OFF to high intensity (0–100 %)
235			Blue	000–255	From OFF to high intensity (0–100 %)
236			White	000–255	From OFF to high intensity (0–100 %)
237	Strip 8	Section 4	Red	000–255	From OFF to high intensity (0–100 %)
238			Green	000–255	From OFF to high intensity (0–100 %)
239			Blue	000–255	From OFF to high intensity (0–100 %)
240			White	000–255	From OFF to high intensity (0–100 %)
241	Strip 8	Section 5	Red	000–255	From OFF to high intensity (0–100 %)
242			Green	000–255	From OFF to high intensity (0–100 %)

CH	Strips	Sections	Function	Value	Setting
243			Blue	000–255	From OFF to high intensity (0–100 %)
244			White	000–255	From OFF to high intensity (0–100 %)
245	Strip 8	Section 6	Red	000–255	From OFF to high intensity (0–100 %)
246			Green	000–255	From OFF to high intensity (0–100 %)
247			Blue	000–255	From OFF to high intensity (0–100 %)
248			White	000–255	From OFF to high intensity (0–100 %)
249	Strip 8	Section 7	Red	000–255	From OFF to high intensity (0–100 %)
250			Green	000–255	From OFF to high intensity (0–100 %)
251			Blue	000–255	From OFF to high intensity (0–100 %)
252			White	000–255	From OFF to high intensity (0–100 %)
253	Strip 8	Section 8	Red	000–255	From OFF to high intensity (0–100 %)
254			Green	000–255	From OFF to high intensity (0–100 %)
255			Blue	000–255	From OFF to high intensity (0–100 %)
256			White	000–255	From OFF to high intensity (0–100 %)

6.7.8. 128 Channels – 0,5 m LED Strips

Make sure that you choose 0.5M in the Led Mode submenu (see [6.6.7.2. Led Mode](#) on page 31) for setups with the 0,5 m version of the LED strips (Product code: [42242](#)).

The 1 m LED strip has 8 sections and the 0,5 m LED strip 4 sections.

Overview of the sections:



Figure 16

128 CH	Strips	Sections	Function	Value	Setting
1	Strip 1	Section 1	Red	000–255	From OFF to high intensity (0–100 %)
2			Green	000–255	From OFF to high intensity (0–100 %)
3			Blue	000–255	From OFF to high intensity (0–100 %)
4			White	000–255	From OFF to high intensity (0–100 %)
5	Strip 1	Section 2	Red	000–255	From OFF to high intensity (0–100 %)
6			Green	000–255	From OFF to high intensity (0–100 %)
7			Blue	000–255	From OFF to high intensity (0–100 %)
8			White	000–255	From OFF to high intensity (0–100 %)
9	Strip 1	Section 3	Red	000–255	From OFF to high intensity (0–100 %)
10			Green	000–255	From OFF to high intensity (0–100 %)
11			Blue	000–255	From OFF to high intensity (0–100 %)
12			White	000–255	From OFF to high intensity (0–100 %)
13	Strip 1	Section 4	Red	000–255	From OFF to high intensity (0–100 %)
14			Green	000–255	From OFF to high intensity (0–100 %)
15			Blue	000–255	From OFF to high intensity (0–100 %)
16			White	000–255	From OFF to high intensity (0–100 %)
17	Strip 2	Section 1	Red	000–255	From OFF to high intensity (0–100 %)

128 CH	Strips	Sections	Function	Value	Setting
18			Green	000-255	From OFF to high intensity (0-100 %)
19			Blue	000-255	From OFF to high intensity (0-100 %)
20			White	000-255	From OFF to high intensity (0-100 %)
21	Strip 2	Section 2	Red	000-255	From OFF to high intensity (0-100 %)
22			Green	000-255	From OFF to high intensity (0-100 %)
23			Blue	000-255	From OFF to high intensity (0-100 %)
24			White	000-255	From OFF to high intensity (0-100 %)
25	Strip 2	Section 3	Red	000-255	From OFF to high intensity (0-100 %)
26			Green	000-255	From OFF to high intensity (0-100 %)
27			Blue	000-255	From OFF to high intensity (0-100 %)
28			White	000-255	From OFF to high intensity (0-100 %)
29	Strip 2	Section 4	Red	000-255	From OFF to high intensity (0-100 %)
30			Green	000-255	From OFF to high intensity (0-100 %)
31			Blue	000-255	From OFF to high intensity (0-100 %)
32			White	000-255	From OFF to high intensity (0-100 %)
33	Strip 3	Section 1	Red	000-255	From OFF to high intensity (0-100 %)
34			Green	000-255	From OFF to high intensity (0-100 %)
35			Blue	000-255	From OFF to high intensity (0-100 %)
36			White	000-255	From OFF to high intensity (0-100 %)
37	Strip 3	Section 2	Red	000-255	From OFF to high intensity (0-100 %)
38			Green	000-255	From OFF to high intensity (0-100 %)
39			Blue	000-255	From OFF to high intensity (0-100 %)
40			White	000-255	From OFF to high intensity (0-100 %)
41	Strip 3	Section 3	Red	000-255	From OFF to high intensity (0-100 %)
42			Green	000-255	From OFF to high intensity (0-100 %)
43			Blue	000-255	From OFF to high intensity (0-100 %)
44			White	000-255	From OFF to high intensity (0-100 %)
45	Strip 3	Section 4	Red	000-255	From OFF to high intensity (0-100 %)
46			Green	000-255	From OFF to high intensity (0-100 %)
47			Blue	000-255	From OFF to high intensity (0-100 %)
48			White	000-255	From OFF to high intensity (0-100 %)
49	Strip 4	Section 1	Red	000-255	From OFF to high intensity (0-100 %)
50			Green	000-255	From OFF to high intensity (0-100 %)
51			Blue	000-255	From OFF to high intensity (0-100 %)
52			White	000-255	From OFF to high intensity (0-100 %)
53	Strip 4	Section 2	Red	000-255	From OFF to high intensity (0-100 %)
54			Green	000-255	From OFF to high intensity (0-100 %)
55			Blue	000-255	From OFF to high intensity (0-100 %)
56			White	000-255	From OFF to high intensity (0-100 %)
57	Strip 4	Section 3	Red	000-255	From OFF to high intensity (0-100 %)
58			Green	000-255	From OFF to high intensity (0-100 %)
59			Blue	000-255	From OFF to high intensity (0-100 %)
60			White	000-255	From OFF to high intensity (0-100 %)
61	Strip 4	Section 4	Red	000-255	From OFF to high intensity (0-100 %)
62			Green	000-255	From OFF to high intensity (0-100 %)
63			Blue	000-255	From OFF to high intensity (0-100 %)
64			White	000-255	From OFF to high intensity (0-100 %)

128 CH	Strips	Sections	Function	Value	Setting
65	Strip 5	Section 1	Red	000–255	From OFF to high intensity (0–100 %)
66			Green	000–255	From OFF to high intensity (0–100 %)
67			Blue	000–255	From OFF to high intensity (0–100 %)
68			White	000–255	From OFF to high intensity (0–100 %)
69	Strip 5	Section 2	Red	000–255	From OFF to high intensity (0–100 %)
70			Green	000–255	From OFF to high intensity (0–100 %)
71			Blue	000–255	From OFF to high intensity (0–100 %)
72			White	000–255	From OFF to high intensity (0–100 %)
73	Strip 5	Section 3	Red	000–255	From OFF to high intensity (0–100 %)
74			Green	000–255	From OFF to high intensity (0–100 %)
75			Blue	000–255	From OFF to high intensity (0–100 %)
76			White	000–255	From OFF to high intensity (0–100 %)
77	Strip 5	Section 4	Red	000–255	From OFF to high intensity (0–100 %)
78			Green	000–255	From OFF to high intensity (0–100 %)
79			Blue	000–255	From OFF to high intensity (0–100 %)
80			White	000–255	From OFF to high intensity (0–100 %)
81	Strip 6	Section 1	Red	000–255	From OFF to high intensity (0–100 %)
82			Green	000–255	From OFF to high intensity (0–100 %)
83			Blue	000–255	From OFF to high intensity (0–100 %)
84			White	000–255	From OFF to high intensity (0–100 %)
85	Strip 6	Section 2	Red	000–255	From OFF to high intensity (0–100 %)
86			Green	000–255	From OFF to high intensity (0–100 %)
87			Blue	000–255	From OFF to high intensity (0–100 %)
88			White	000–255	From OFF to high intensity (0–100 %)
89	Strip 6	Section 3	Red	000–255	From OFF to high intensity (0–100 %)
90			Green	000–255	From OFF to high intensity (0–100 %)
91			Blue	000–255	From OFF to high intensity (0–100 %)
92			White	000–255	From OFF to high intensity (0–100 %)
93	Strip 6	Section 4	Red	000–255	From OFF to high intensity (0–100 %)
94			Green	000–255	From OFF to high intensity (0–100 %)
95			Blue	000–255	From OFF to high intensity (0–100 %)
96			White	000–255	From OFF to high intensity (0–100 %)
97	Strip 7	Section 1	Red	000–255	From OFF to high intensity (0–100 %)
98			Green	000–255	From OFF to high intensity (0–100 %)
99			Blue	000–255	From OFF to high intensity (0–100 %)
100			White	000–255	From OFF to high intensity (0–100 %)
101	Strip 7	Section 2	Red	000–255	From OFF to high intensity (0–100 %)
102			Green	000–255	From OFF to high intensity (0–100 %)
103			Blue	000–255	From OFF to high intensity (0–100 %)
104			White	000–255	From OFF to high intensity (0–100 %)
105	Strip 7	Section 3	Red	000–255	From OFF to high intensity (0–100 %)
106			Green	000–255	From OFF to high intensity (0–100 %)
107			Blue	000–255	From OFF to high intensity (0–100 %)
108			White	000–255	From OFF to high intensity (0–100 %)
109	Strip 7	Section 4	Red	000–255	From OFF to high intensity (0–100 %)
110			Green	000–255	From OFF to high intensity (0–100 %)
111			Blue	000–255	From OFF to high intensity (0–100 %)

128 CH	Strips	Sections	Function	Value	Setting
112			White	000–255	From OFF to high intensity (0–100 %)
113	Strip 8	Section 1	Red	000–255	From OFF to high intensity (0–100 %)
114			Green	000–255	From OFF to high intensity (0–100 %)
115			Blue	000–255	From OFF to high intensity (0–100 %)
116			White	000–255	From OFF to high intensity (0–100 %)
117	Strip 8	Section 2	Red	000–255	From OFF to high intensity (0–100 %)
118			Green	000–255	From OFF to high intensity (0–100 %)
119			Blue	000–255	From OFF to high intensity (0–100 %)
120			White	000–255	From OFF to high intensity (0–100 %)
121	Strip 8	Section 3	Red	000–255	From OFF to high intensity (0–100 %)
122			Green	000–255	From OFF to high intensity (0–100 %)
123			Blue	000–255	From OFF to high intensity (0–100 %)
124			White	000–255	From OFF to high intensity (0–100 %)
125	Strip 8	Section 4	Red	000–255	From OFF to high intensity (0–100 %)
126			Green	000–255	From OFF to high intensity (0–100 %)
127			Blue	000–255	From OFF to high intensity (0–100 %)
128			White	000–255	From OFF to high intensity (0–100 %)

6.7.9. 384 Channels – 1 m LED Strips

Make sure that you choose 1.0M in the Led Mode submenu (see [6.6.7.2. Led Mode](#) on page 31) for setups with the 1 m version of the LED strips (Product code: [42237](#)).

The 1 m LED strip has 8 sections and the 0,5 m LED strip 4 sections.

Overview of the sections:

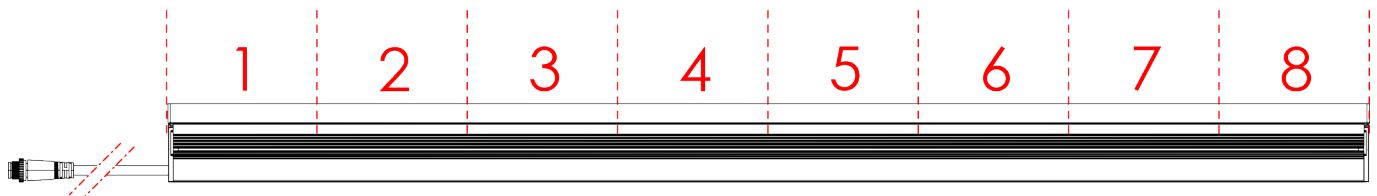

Figure 17

384 CH	Strip	Section	Function	Value	Setting
1	Strip 1	Section 1	Dimmer	000–255	From OFF to high intensity (0–100 %)
2			Strobe	000–004	No function
				005–255	From low to high frequency
3			Red	000–255	From OFF to high intensity (0–100 %)
4			Green	000–255	From OFF to high intensity (0–100 %)
5			Blue	000–255	From OFF to high intensity (0–100 %)
6			White	000–255	From OFF to high intensity (0–100 %)
7	Strip 1	Section 2	Dimmer	000–255	From OFF to high intensity (0–100 %)
8			Strobe	000–004	No function
				005–255	From low to high frequency
9			Red	000–255	From OFF to high intensity (0–100 %)
10			Green	000–255	From OFF to high intensity (0–100 %)
11			Blue	000–255	From OFF to high intensity (0–100 %)
12			White	000–255	From OFF to high intensity (0–100 %)
13	Strip 1	Section 3	Dimmer	000–255	From OFF to high intensity (0–100 %)

384 CH	Strip	Section	Function	Value	Setting
14			Strobe	000-004	No function
				005-255	From low to high frequency
15			Red	000-255	From OFF to high intensity (0-100 %)
16			Green	000-255	From OFF to high intensity (0-100 %)
17			Blue	000-255	From OFF to high intensity (0-100 %)
18			White	000-255	From OFF to high intensity (0-100 %)
19	Strip 1	Section 4	Dimmer	000-255	From OFF to high intensity (0-100 %)
20			Strobe	000-004	No function
				005-255	From low to high frequency
21			Red	000-255	From OFF to high intensity (0-100 %)
22			Green	000-255	From OFF to high intensity (0-100 %)
23			Blue	000-255	From OFF to high intensity (0-100 %)
24			White	000-255	From OFF to high intensity (0-100 %)
25	Strip 1	Section 5	Dimmer	000-255	From OFF to high intensity (0-100 %)
26			Strobe	000-004	No function
				005-255	From low to high frequency
27			Red	000-255	From OFF to high intensity (0-100 %)
28			Green	000-255	From OFF to high intensity (0-100 %)
29			Blue	000-255	From OFF to high intensity (0-100 %)
30			White	000-255	From OFF to high intensity (0-100 %)
31	Strip 1	Section 6	Dimmer	000-255	From OFF to high intensity (0-100 %)
32			Strobe	000-004	No function
				005-255	From low to high frequency
33			Red	000-255	From OFF to high intensity (0-100 %)
34			Green	000-255	From OFF to high intensity (0-100 %)
35			Blue	000-255	From OFF to high intensity (0-100 %)
36			White	000-255	From OFF to high intensity (0-100 %)
37	Strip 1	Section 7	Dimmer	000-255	From OFF to high intensity (0-100 %)
38			Strobe	000-004	No function
				005-255	From low to high frequency
39			Red	000-255	From OFF to high intensity (0-100 %)
40			Green	000-255	From OFF to high intensity (0-100 %)
41			Blue	000-255	From OFF to high intensity (0-100 %)
42			White	000-255	From OFF to high intensity (0-100 %)
43	Strip 1	Section 8	Dimmer	000-255	From OFF to high intensity (0-100 %)
44			Strobe	000-004	No function
				005-255	From low to high frequency
45			Red	000-255	From OFF to high intensity (0-100 %)
46			Green	000-255	From OFF to high intensity (0-100 %)
47			Blue	000-255	From OFF to high intensity (0-100 %)
48			White	000-255	From OFF to high intensity (0-100 %)
49	Strip 2	Section 1	Dimmer	000-255	From OFF to high intensity (0-100 %)
50			Strobe	000-004	No function
				005-255	From low to high frequency
51			Red	000-255	From OFF to high intensity (0-100 %)
52			Green	000-255	From OFF to high intensity (0-100 %)
53			Blue	000-255	From OFF to high intensity (0-100 %)

384 CH	Strip	Section	Function	Value	Setting
54			White	000–255	From OFF to high intensity (0–100 %)
55	Strip 2	Section 2	Dimmer	000–255	From OFF to high intensity (0–100 %)
56			Strobe	000–004	No function
				005–255	From low to high frequency
57			Red	000–255	From OFF to high intensity (0–100 %)
58			Green	000–255	From OFF to high intensity (0–100 %)
59			Blue	000–255	From OFF to high intensity (0–100 %)
60			White	000–255	From OFF to high intensity (0–100 %)
61	Strip 2	Section 3	Dimmer	000–255	From OFF to high intensity (0–100 %)
62			Strobe	000–004	No function
				005–255	From low to high frequency
63			Red	000–255	From OFF to high intensity (0–100 %)
64			Green	000–255	From OFF to high intensity (0–100 %)
65			Blue	000–255	From OFF to high intensity (0–100 %)
66			White	000–255	From OFF to high intensity (0–100 %)
67	Strip 2	Section 4	Dimmer	000–255	From OFF to high intensity (0–100 %)
68			Strobe	000–004	No function
				005–255	From low to high frequency
69			Red	000–255	From OFF to high intensity (0–100 %)
70			Green	000–255	From OFF to high intensity (0–100 %)
71			Blue	000–255	From OFF to high intensity (0–100 %)
72			White	000–255	From OFF to high intensity (0–100 %)
73	Strip 2	Section 5	Dimmer	000–255	From OFF to high intensity (0–100 %)
74			Strobe	000–004	No function
				005–255	From low to high frequency
75			Red	000–255	From OFF to high intensity (0–100 %)
76			Green	000–255	From OFF to high intensity (0–100 %)
77			Blue	000–255	From OFF to high intensity (0–100 %)
78			White	000–255	From OFF to high intensity (0–100 %)
79	Strip 2	Section 6	Dimmer	000–255	From OFF to high intensity (0–100 %)
80			Strobe	000–004	No function
				005–255	From low to high frequency
81			Red	000–255	From OFF to high intensity (0–100 %)
82			Green	000–255	From OFF to high intensity (0–100 %)
83			Blue	000–255	From OFF to high intensity (0–100 %)
84			White	000–255	From OFF to high intensity (0–100 %)
85	Strip 2	Section 7	Dimmer	000–255	From OFF to high intensity (0–100 %)
86			Strobe	000–004	No function
				005–255	From low to high frequency
87			Red	000–255	From OFF to high intensity (0–100 %)
88			Green	000–255	From OFF to high intensity (0–100 %)
89			Blue	000–255	From OFF to high intensity (0–100 %)
90			White	000–255	From OFF to high intensity (0–100 %)
91	Strip 2	Section 8	Dimmer	000–255	From OFF to high intensity (0–100 %)
92			Strobe	000–004	No function
				005–255	From low to high frequency
93			Red	000–255	From OFF to high intensity (0–100 %)

384 CH	Strip	Section	Function	Value	Setting
94			Green	000–255	From OFF to high intensity (0–100 %)
95			Blue	000–255	From OFF to high intensity (0–100 %)
96			White	000–255	From OFF to high intensity (0–100 %)
97	Strip 3	Section 1	Dimmer	000–255	From OFF to high intensity (0–100 %)
98			Strobe	000–004	No function
				005–255	From low to high frequency
99			Red	000–255	From OFF to high intensity (0–100 %)
100			Green	000–255	From OFF to high intensity (0–100 %)
101			Blue	000–255	From OFF to high intensity (0–100 %)
102			White	000–255	From OFF to high intensity (0–100 %)
103	Strip 3	Section 2	Dimmer	000–255	From OFF to high intensity (0–100 %)
104			Strobe	000–004	No function
				005–255	From low to high frequency
105			Red	000–255	From OFF to high intensity (0–100 %)
106			Green	000–255	From OFF to high intensity (0–100 %)
107			Blue	000–255	From OFF to high intensity (0–100 %)
108			White	000–255	From OFF to high intensity (0–100 %)
109	Strip 3	Section 3	Dimmer	000–255	From OFF to high intensity (0–100 %)
110			Strobe	000–004	No function
				005–255	From low to high frequency
111			Red	000–255	From OFF to high intensity (0–100 %)
112			Green	000–255	From OFF to high intensity (0–100 %)
113			Blue	000–255	From OFF to high intensity (0–100 %)
114			White	000–255	From OFF to high intensity (0–100 %)
115	Strip 3	Section 4	Dimmer	000–255	From OFF to high intensity (0–100 %)
116			Strobe	000–004	No function
				005–255	From low to high frequency
117			Red	000–255	From OFF to high intensity (0–100 %)
118			Green	000–255	From OFF to high intensity (0–100 %)
119			Blue	000–255	From OFF to high intensity (0–100 %)
120			White	000–255	From OFF to high intensity (0–100 %)
121	Strip 3	Section 5	Dimmer	000–255	From OFF to high intensity (0–100 %)
122			Strobe	000–004	No function
				005–255	From low to high frequency
123			Red	000–255	From OFF to high intensity (0–100 %)
124			Green	000–255	From OFF to high intensity (0–100 %)
125			Blue	000–255	From OFF to high intensity (0–100 %)
126			White	000–255	From OFF to high intensity (0–100 %)
127	Strip 3	Section 6	Dimmer	000–255	From OFF to high intensity (0–100 %)
128			Strobe	000–004	No function
				005–255	From low to high frequency
129			Red	000–255	From OFF to high intensity (0–100 %)
130			Green	000–255	From OFF to high intensity (0–100 %)
131			Blue	000–255	From OFF to high intensity (0–100 %)
132			White	000–255	From OFF to high intensity (0–100 %)
133	Strip 3	Section 7	Dimmer	000–255	From OFF to high intensity (0–100 %)
134			Strobe	000–004	No function

384 CH	Strip	Section	Function	Value	Setting
				005–255	From low to high frequency
135			Red	000–255	From OFF to high intensity (0–100 %)
136			Green	000–255	From OFF to high intensity (0–100 %)
137			Blue	000–255	From OFF to high intensity (0–100 %)
138			White	000–255	From OFF to high intensity (0–100 %)
139	Strip 3	Section 8	Dimmer	000–255	From OFF to high intensity (0–100 %)
140			Strobe	000–004	No function
				005–255	From low to high frequency
141			Red	000–255	From OFF to high intensity (0–100 %)
142			Green	000–255	From OFF to high intensity (0–100 %)
143			Blue	000–255	From OFF to high intensity (0–100 %)
144			White	000–255	From OFF to high intensity (0–100 %)
145	Strip 4	Section 1	Dimmer	000–255	From OFF to high intensity (0–100 %)
146			Strobe	000–004	No function
				005–255	From low to high frequency
147			Red	000–255	From OFF to high intensity (0–100 %)
148			Green	000–255	From OFF to high intensity (0–100 %)
149			Blue	000–255	From OFF to high intensity (0–100 %)
150			White	000–255	From OFF to high intensity (0–100 %)
151	Strip 4	Section 2	Dimmer	000–255	From OFF to high intensity (0–100 %)
152			Strobe	000–004	No function
				005–255	From low to high frequency
153			Red	000–255	From OFF to high intensity (0–100 %)
154			Green	000–255	From OFF to high intensity (0–100 %)
155			Blue	000–255	From OFF to high intensity (0–100 %)
156			White	000–255	From OFF to high intensity (0–100 %)
157	Strip 4	Section 3	Dimmer	000–255	From OFF to high intensity (0–100 %)
158			Strobe	000–004	No function
				005–255	From low to high frequency
159			Red	000–255	From OFF to high intensity (0–100 %)
160			Green	000–255	From OFF to high intensity (0–100 %)
161			Blue	000–255	From OFF to high intensity (0–100 %)
162			White	000–255	From OFF to high intensity (0–100 %)
163	Strip 4	Section 4	Dimmer	000–255	From OFF to high intensity (0–100 %)
164			Strobe	000–004	No function
				005–255	From low to high frequency
165			Red	000–255	From OFF to high intensity (0–100 %)
166			Green	000–255	From OFF to high intensity (0–100 %)
167			Blue	000–255	From OFF to high intensity (0–100 %)
168			White	000–255	From OFF to high intensity (0–100 %)
169	Strip 4	Section 5	Dimmer	000–255	From OFF to high intensity (0–100 %)
170			Strobe	000–004	No function
				005–255	From low to high frequency
171			Red	000–255	From OFF to high intensity (0–100 %)
172			Green	000–255	From OFF to high intensity (0–100 %)
173			Blue	000–255	From OFF to high intensity (0–100 %)
174			White	000–255	From OFF to high intensity (0–100 %)

384 CH	Strip	Section	Function	Value	Setting
175	Strip 4	Section 6	Dimmer	000–255	From OFF to high intensity (0–100 %)
176			Strobe	000–004 005–255	No function From low to high frequency
177			Red	000–255	From OFF to high intensity (0–100 %)
178			Green	000–255	From OFF to high intensity (0–100 %)
179			Blue	000–255	From OFF to high intensity (0–100 %)
180			White	000–255	From OFF to high intensity (0–100 %)
181	Strip 4	Section 7	Dimmer	000–255	From OFF to high intensity (0–100 %)
182			Strobe	000–004 005–255	No function From low to high frequency
183			Red	000–255	From OFF to high intensity (0–100 %)
184			Green	000–255	From OFF to high intensity (0–100 %)
185			Blue	000–255	From OFF to high intensity (0–100 %)
186			White	000–255	From OFF to high intensity (0–100 %)
187	Strip 4	Section 8	Dimmer	000–255	From OFF to high intensity (0–100 %)
188			Strobe	000–004 005–255	No function From low to high frequency
189			Red	000–255	From OFF to high intensity (0–100 %)
190			Green	000–255	From OFF to high intensity (0–100 %)
191			Blue	000–255	From OFF to high intensity (0–100 %)
192			White	000–255	From OFF to high intensity (0–100 %)
193	Strip 5	Section 1	Dimmer	000–255	From OFF to high intensity (0–100 %)
194			Strobe	000–004 005–255	No function From low to high frequency
195			Red	000–255	From OFF to high intensity (0–100 %)
196			Green	000–255	From OFF to high intensity (0–100 %)
197			Blue	000–255	From OFF to high intensity (0–100 %)
198			White	000–255	From OFF to high intensity (0–100 %)
199	Strip 5	Section 2	Dimmer	000–255	From OFF to high intensity (0–100 %)
200			Strobe	000–004 005–255	No function From low to high frequency
201			Red	000–255	From OFF to high intensity (0–100 %)
202			Green	000–255	From OFF to high intensity (0–100 %)
203			Blue	000–255	From OFF to high intensity (0–100 %)
204			White	000–255	From OFF to high intensity (0–100 %)
205	Strip 5	Section 3	Dimmer	000–255	From OFF to high intensity (0–100 %)
206			Strobe	000–004 005–255	No function From low to high frequency
207			Red	000–255	From OFF to high intensity (0–100 %)
208			Green	000–255	From OFF to high intensity (0–100 %)
209			Blue	000–255	From OFF to high intensity (0–100 %)
210			White	000–255	From OFF to high intensity (0–100 %)
211	Strip 5	Section 4	Dimmer	000–255	From OFF to high intensity (0–100 %)
212			Strobe	000–004 005–255	No function From low to high frequency
213			Red	000–255	From OFF to high intensity (0–100 %)
214			Green	000–255	From OFF to high intensity (0–100 %)

384 CH	Strip	Section	Function	Value	Setting
215			Blue	000–255	From OFF to high intensity (0–100 %)
216			White	000–255	From OFF to high intensity (0–100 %)
217	Strip 5	Section 5	Dimmer	000–255	From OFF to high intensity (0–100 %)
218					
			Strobe	005–255	From low to high frequency
219			Red	000–255	From OFF to high intensity (0–100 %)
220			Green	000–255	From OFF to high intensity (0–100 %)
221			Blue	000–255	From OFF to high intensity (0–100 %)
222			White	000–255	From OFF to high intensity (0–100 %)
223	Strip 5	Section 6	Dimmer	000–255	From OFF to high intensity (0–100 %)
224					
			Strobe	005–255	From low to high frequency
225			Red	000–255	From OFF to high intensity (0–100 %)
226			Green	000–255	From OFF to high intensity (0–100 %)
227			Blue	000–255	From OFF to high intensity (0–100 %)
228			White	000–255	From OFF to high intensity (0–100 %)
229	Strip 5	Section 7	Dimmer	000–255	From OFF to high intensity (0–100 %)
230					
			Strobe	005–255	From low to high frequency
231			Red	000–255	From OFF to high intensity (0–100 %)
232			Green	000–255	From OFF to high intensity (0–100 %)
233			Blue	000–255	From OFF to high intensity (0–100 %)
234			White	000–255	From OFF to high intensity (0–100 %)
235	Strip 5	Section 8	Dimmer	000–255	From OFF to high intensity (0–100 %)
236					
			Strobe	005–255	From low to high frequency
237			Red	000–255	From OFF to high intensity (0–100 %)
238			Green	000–255	From OFF to high intensity (0–100 %)
239			Blue	000–255	From OFF to high intensity (0–100 %)
240			White	000–255	From OFF to high intensity (0–100 %)
241	Strip 6	Section 1	Dimmer	000–255	From OFF to high intensity (0–100 %)
242					
			Strobe	005–255	From low to high frequency
243			Red	000–255	From OFF to high intensity (0–100 %)
244			Green	000–255	From OFF to high intensity (0–100 %)
245			Blue	000–255	From OFF to high intensity (0–100 %)
246			White	000–255	From OFF to high intensity (0–100 %)
247	Strip 6	Section 2	Dimmer	000–255	From OFF to high intensity (0–100 %)
248					
			Strobe	005–255	From low to high frequency
249			Red	000–255	From OFF to high intensity (0–100 %)
250			Green	000–255	From OFF to high intensity (0–100 %)
251			Blue	000–255	From OFF to high intensity (0–100 %)
252			White	000–255	From OFF to high intensity (0–100 %)
253	Strip 6	Section 3	Dimmer	000–255	From OFF to high intensity (0–100 %)
254					
			Strobe	005–255	From low to high frequency

384 CH	Strip	Section	Function	Value	Setting
255			Red	000–255	From OFF to high intensity (0–100 %)
256			Green	000–255	From OFF to high intensity (0–100 %)
257			Blue	000–255	From OFF to high intensity (0–100 %)
258			White	000–255	From OFF to high intensity (0–100 %)
259	Strip 6	Section 4	Dimmer	000–255	From OFF to high intensity (0–100 %)
260			Strobe	000–004	No function
				005–255	From low to high frequency
261			Red	000–255	From OFF to high intensity (0–100 %)
262			Green	000–255	From OFF to high intensity (0–100 %)
263			Blue	000–255	From OFF to high intensity (0–100 %)
264			White	000–255	From OFF to high intensity (0–100 %)
265	Strip 6	Section 5	Dimmer	000–255	From OFF to high intensity (0–100 %)
266			Strobe	000–004	No function
				005–255	From low to high frequency
267			Red	000–255	From OFF to high intensity (0–100 %)
268			Green	000–255	From OFF to high intensity (0–100 %)
269			Blue	000–255	From OFF to high intensity (0–100 %)
270			White	000–255	From OFF to high intensity (0–100 %)
271	Strip 6	Section 6	Dimmer	000–255	From OFF to high intensity (0–100 %)
272			Strobe	000–004	No function
				005–255	From low to high frequency
273			Red	000–255	From OFF to high intensity (0–100 %)
274			Green	000–255	From OFF to high intensity (0–100 %)
275			Blue	000–255	From OFF to high intensity (0–100 %)
276			White	000–255	From OFF to high intensity (0–100 %)
277	Strip 6	Section 7	Dimmer	000–255	From OFF to high intensity (0–100 %)
278			Strobe	000–004	No function
				005–255	From low to high frequency
279			Red	000–255	From OFF to high intensity (0–100 %)
280			Green	000–255	From OFF to high intensity (0–100 %)
281			Blue	000–255	From OFF to high intensity (0–100 %)
282			White	000–255	From OFF to high intensity (0–100 %)
283	Strip 6	Section 8	Dimmer	000–255	From OFF to high intensity (0–100 %)
284			Strobe	000–004	No function
				005–255	From low to high frequency
285			Red	000–255	From OFF to high intensity (0–100 %)
286			Green	000–255	From OFF to high intensity (0–100 %)
287			Blue	000–255	From OFF to high intensity (0–100 %)
288			White	000–255	From OFF to high intensity (0–100 %)
289	Strip 7	Section 1	Dimmer	000–255	From OFF to high intensity (0–100 %)
290			Strobe	000–004	No function
				005–255	From low to high frequency
291			Red	000–255	From OFF to high intensity (0–100 %)
292			Green	000–255	From OFF to high intensity (0–100 %)
293			Blue	000–255	From OFF to high intensity (0–100 %)
294			White	000–255	From OFF to high intensity (0–100 %)
295	Strip 7	Section 2	Dimmer	000–255	From OFF to high intensity (0–100 %)

384 CH	Strip	Section	Function	Value	Setting
296			Strobe	000-004	No function
				005-255	From low to high frequency
297			Red	000-255	From OFF to high intensity (0-100 %)
298			Green	000-255	From OFF to high intensity (0-100 %)
299			Blue	000-255	From OFF to high intensity (0-100 %)
300			White	000-255	From OFF to high intensity (0-100 %)
301	Strip 7	Section 3	Dimmer	000-255	From OFF to high intensity (0-100 %)
302			Strobe	000-004	No function
				005-255	From low to high frequency
303			Red	000-255	From OFF to high intensity (0-100 %)
304			Green	000-255	From OFF to high intensity (0-100 %)
305			Blue	000-255	From OFF to high intensity (0-100 %)
306			White	000-255	From OFF to high intensity (0-100 %)
307	Strip 7	Section 4	Dimmer	000-255	From OFF to high intensity (0-100 %)
308			Strobe	000-004	No function
				005-255	From low to high frequency
309			Red	000-255	From OFF to high intensity (0-100 %)
310			Green	000-255	From OFF to high intensity (0-100 %)
311			Blue	000-255	From OFF to high intensity (0-100 %)
312			White	000-255	From OFF to high intensity (0-100 %)
313	Strip 7	Section 5	Dimmer	000-255	From OFF to high intensity (0-100 %)
314			Strobe	000-004	No function
				005-255	From low to high frequency
315			Red	000-255	From OFF to high intensity (0-100 %)
316			Green	000-255	From OFF to high intensity (0-100 %)
317			Blue	000-255	From OFF to high intensity (0-100 %)
318			White	000-255	From OFF to high intensity (0-100 %)
319	Strip 7	Section 6	Dimmer	000-255	From OFF to high intensity (0-100 %)
320			Strobe	000-004	No function
				005-255	From low to high frequency
321			Red	000-255	From OFF to high intensity (0-100 %)
322			Green	000-255	From OFF to high intensity (0-100 %)
323			Blue	000-255	From OFF to high intensity (0-100 %)
324			White	000-255	From OFF to high intensity (0-100 %)
325	Strip 7	Section 7	Dimmer	000-255	From OFF to high intensity (0-100 %)
326			Strobe	000-004	No function
				005-255	From low to high frequency
327			Red	000-255	From OFF to high intensity (0-100 %)
328			Green	000-255	From OFF to high intensity (0-100 %)
329			Blue	000-255	From OFF to high intensity (0-100 %)
330			White	000-255	From OFF to high intensity (0-100 %)
331	Strip 7	Section 8	Dimmer	000-255	From OFF to high intensity (0-100 %)
332			Strobe	000-004	No function
				005-255	From low to high frequency
333			Red	000-255	From OFF to high intensity (0-100 %)
334			Green	000-255	From OFF to high intensity (0-100 %)
335			Blue	000-255	From OFF to high intensity (0-100 %)

384 CH	Strip	Section	Function	Value	Setting
336			White	000–255	From OFF to high intensity (0–100 %)
337	Strip 8	Section 1	Dimmer	000–255	From OFF to high intensity (0–100 %)
338			Strobe	000–004	No function
				005–255	From low to high frequency
339			Red	000–255	From OFF to high intensity (0–100 %)
340			Green	000–255	From OFF to high intensity (0–100 %)
341			Blue	000–255	From OFF to high intensity (0–100 %)
342			White	000–255	From OFF to high intensity (0–100 %)
343	Strip 8	Section 2	Dimmer	000–255	From OFF to high intensity (0–100 %)
344			Strobe	000–004	No function
				005–255	From low to high frequency
345			Red	000–255	From OFF to high intensity (0–100 %)
346			Green	000–255	From OFF to high intensity (0–100 %)
347			Blue	000–255	From OFF to high intensity (0–100 %)
348			White	000–255	From OFF to high intensity (0–100 %)
349	Strip 8	Section 3	Dimmer	000–255	From OFF to high intensity (0–100 %)
350			Strobe	000–004	No function
				005–255	From low to high frequency
351			Red	000–255	From OFF to high intensity (0–100 %)
352			Green	000–255	From OFF to high intensity (0–100 %)
353			Blue	000–255	From OFF to high intensity (0–100 %)
354			White	000–255	From OFF to high intensity (0–100 %)
355	Strip 8	Section 4	Dimmer	000–255	From OFF to high intensity (0–100 %)
356			Strobe	000–004	No function
				005–255	From low to high frequency
357			Red	000–255	From OFF to high intensity (0–100 %)
358			Green	000–255	From OFF to high intensity (0–100 %)
359			Blue	000–255	From OFF to high intensity (0–100 %)
360			White	000–255	From OFF to high intensity (0–100 %)
361	Strip 8	Section 5	Dimmer	000–255	From OFF to high intensity (0–100 %)
362			Strobe	000–004	No function
				005–255	From low to high frequency
363			Red	000–255	From OFF to high intensity (0–100 %)
364			Green	000–255	From OFF to high intensity (0–100 %)
365			Blue	000–255	From OFF to high intensity (0–100 %)
366			White	000–255	From OFF to high intensity (0–100 %)
367	Strip 8	Section 6	Dimmer	000–255	From OFF to high intensity (0–100 %)
368			Strobe	000–004	No function
				005–255	From low to high frequency
369			Red	000–255	From OFF to high intensity (0–100 %)
370			Green	000–255	From OFF to high intensity (0–100 %)
371			Blue	000–255	From OFF to high intensity (0–100 %)
372			White	000–255	From OFF to high intensity (0–100 %)
373	Strip 8	Section 7	Dimmer	000–255	From OFF to high intensity (0–100 %)
374			Strobe	000–004	No function
				005–255	From low to high frequency
375			Red	000–255	From OFF to high intensity (0–100 %)

384 CH	Strip	Section	Function	Value	Setting
376			Green	000–255	From OFF to high intensity (0–100 %)
377			Blue	000–255	From OFF to high intensity (0–100 %)
378			White	000–255	From OFF to high intensity (0–100 %)
379	Strip 8	Section 8	Dimmer	000–255	From OFF to high intensity (0–100 %)
380			Strobe	000–004	No function
				005–255	From low to high frequency
381			Red	000–255	From OFF to high intensity (0–100 %)
382			Green	000–255	From OFF to high intensity (0–100 %)
383			Blue	000–255	From OFF to high intensity (0–100 %)
384			White	000–255	From OFF to high intensity (0–100 %)

6.7.10. 192 Channels – 0,5 m LED Strips

Make sure that you choose 0.5M in the Led Mode submenu (see [6.6.7.2. Led Mode](#) on page 31) for setups with the 0,5 m version of the LED strips (Product code: [42242](#)).

The 1 m LED strip has 8 sections and the 0,5 m LED strip 4 sections.

Overview of the sections:

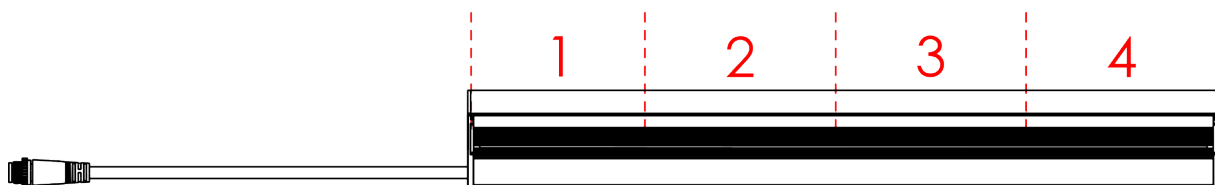

Figure 18

192 CH	Strip	Section	Function	Value	Setting
1	Strip 1	Section 1	Dimmer	000–255	From OFF to high intensity (0–100 %)
2			Strobe	000–004	No function
				005–255	From low to high frequency
3			Red	000–255	From OFF to high intensity (0–100 %)
4			Green	000–255	From OFF to high intensity (0–100 %)
5			Blue	000–255	From OFF to high intensity (0–100 %)
6			White	000–255	From OFF to high intensity (0–100 %)
7	Strip 1	Section 2	Dimmer	000–255	From OFF to high intensity (0–100 %)
8			Strobe	000–004	No function
				005–255	From low to high frequency
9			Red	000–255	From OFF to high intensity (0–100 %)
10			Green	000–255	From OFF to high intensity (0–100 %)
11			Blue	000–255	From OFF to high intensity (0–100 %)
12			White	000–255	From OFF to high intensity (0–100 %)
13	Strip 1	Section 3	Dimmer	000–255	From OFF to high intensity (0–100 %)
14			Strobe	000–004	No function
				005–255	From low to high frequency
15			Red	000–255	From OFF to high intensity (0–100 %)
16			Green	000–255	From OFF to high intensity (0–100 %)
17			Blue	000–255	From OFF to high intensity (0–100 %)
19			White	000–255	From OFF to high intensity (0–100 %)

192 CH	Strip	Section	Function	Value	Setting
19	Strip 1	Section 4	Dimmer	000–255	From OFF to high intensity (0–100 %)
20			Strobe	000–004 005–255	No function From low to high frequency
21			Red	000–255	From OFF to high intensity (0–100 %)
22			Green	000–255	From OFF to high intensity (0–100 %)
23			Blue	000–255	From OFF to high intensity (0–100 %)
24			White	000–255	From OFF to high intensity (0–100 %)
25	Strip 2	Section 1	Dimmer	000–255	From OFF to high intensity (0–100 %)
26			Strobe	000–004 005–255	No function From low to high frequency
27			Red	000–255	From OFF to high intensity (0–100 %)
28			Green	000–255	From OFF to high intensity (0–100 %)
29			Blue	000–255	From OFF to high intensity (0–100 %)
30			White	000–255	From OFF to high intensity (0–100 %)
31	Strip 2	Section 2	Dimmer	000–255	From OFF to high intensity (0–100 %)
32			Strobe	000–004 005–255	No function From low to high frequency
33			Red	000–255	From OFF to high intensity (0–100 %)
34			Green	000–255	From OFF to high intensity (0–100 %)
35			Blue	000–255	From OFF to high intensity (0–100 %)
36			White	000–255	From OFF to high intensity (0–100 %)
37	Strip 2	Section 3	Dimmer	000–255	From OFF to high intensity (0–100 %)
38			Strobe	000–004 005–255	No function From low to high frequency
39			Red	000–255	From OFF to high intensity (0–100 %)
40			Green	000–255	From OFF to high intensity (0–100 %)
41			Blue	000–255	From OFF to high intensity (0–100 %)
42			White	000–255	From OFF to high intensity (0–100 %)
43	Strip 2	Section 4	Dimmer	000–255	From OFF to high intensity (0–100 %)
44			Strobe	000–004 005–255	No function From low to high frequency
45			Red	000–255	From OFF to high intensity (0–100 %)
46			Green	000–255	From OFF to high intensity (0–100 %)
47			Blue	000–255	From OFF to high intensity (0–100 %)
48			White	000–255	From OFF to high intensity (0–100 %)
49	Strip 3	Section 1	Dimmer	000–255	From OFF to high intensity (0–100 %)
50			Strobe	000–004 005–255	No function From low to high frequency
51			Red	000–255	From OFF to high intensity (0–100 %)
52			Green	000–255	From OFF to high intensity (0–100 %)
53			Blue	000–255	From OFF to high intensity (0–100 %)
54			White	000–255	From OFF to high intensity (0–100 %)
55	Strip 3	Section 2	Dimmer	000–255	From OFF to high intensity (0–100 %)
56			Strobe	000–004 005–255	No function From low to high frequency
57			Red	000–255	From OFF to high intensity (0–100 %)
58			Green	000–255	From OFF to high intensity (0–100 %)

192 CH	Strip	Section	Function	Value	Setting
59			Blue	000–255	From OFF to high intensity (0–100 %)
60			White	000–255	From OFF to high intensity (0–100 %)
61	Strip 3	Section 3	Dimmer	000–255	From OFF to high intensity (0–100 %)
62			Strobe	000–004	No function
				005–255	From low to high frequency
63			Red	000–255	From OFF to high intensity (0–100 %)
64			Green	000–255	From OFF to high intensity (0–100 %)
65			Blue	000–255	From OFF to high intensity (0–100 %)
66			White	000–255	From OFF to high intensity (0–100 %)
67	Strip 3	Section 4	Dimmer	000–255	From OFF to high intensity (0–100 %)
68			Strobe	000–004	No function
				005–255	From low to high frequency
69			Red	000–255	From OFF to high intensity (0–100 %)
70			Green	000–255	From OFF to high intensity (0–100 %)
71			Blue	000–255	From OFF to high intensity (0–100 %)
72			White	000–255	From OFF to high intensity (0–100 %)
73	Strip 4	Section 1	Dimmer	000–255	From OFF to high intensity (0–100 %)
74			Strobe	000–004	No function
				005–255	From low to high frequency
75			Red	000–255	From OFF to high intensity (0–100 %)
76			Green	000–255	From OFF to high intensity (0–100 %)
77			Blue	000–255	From OFF to high intensity (0–100 %)
78			White	000–255	From OFF to high intensity (0–100 %)
79	Strip 4	Section 2	Dimmer	000–255	From OFF to high intensity (0–100 %)
80			Strobe	000–004	No function
				005–255	From low to high frequency
81			Red	000–255	From OFF to high intensity (0–100 %)
82			Green	000–255	From OFF to high intensity (0–100 %)
83			Blue	000–255	From OFF to high intensity (0–100 %)
84			White	000–255	From OFF to high intensity (0–100 %)
85	Strip 4	Section 3	Dimmer	000–255	From OFF to high intensity (0–100 %)
86			Strobe	000–004	No function
				005–255	From low to high frequency
87			Red	000–255	From OFF to high intensity (0–100 %)
88			Green	000–255	From OFF to high intensity (0–100 %)
89			Blue	000–255	From OFF to high intensity (0–100 %)
90			White	000–255	From OFF to high intensity (0–100 %)
91	Strip 4	Section 4	Dimmer	000–255	From OFF to high intensity (0–100 %)
92			Strobe	000–004	No function
				005–255	From low to high frequency
93			Red	000–255	From OFF to high intensity (0–100 %)
94			Green	000–255	From OFF to high intensity (0–100 %)
95			Blue	000–255	From OFF to high intensity (0–100 %)
96			White	000–255	From OFF to high intensity (0–100 %)
97	Strip 5	Section 1	Dimmer	000–255	From OFF to high intensity (0–100 %)
98			Strobe	000–004	No function
				005–255	From low to high frequency

192 CH	Strip	Section	Function	Value	Setting
99			Red	000–255	From OFF to high intensity (0–100 %)
100			Green	000–255	From OFF to high intensity (0–100 %)
101			Blue	000–255	From OFF to high intensity (0–100 %)
102			White	000–255	From OFF to high intensity (0–100 %)
103	Strip 5	Section 2	Dimmer	000–255	From OFF to high intensity (0–100 %)
104			Strobe	000–004	No function
				005–255	From low to high frequency
105			Red	000–255	From OFF to high intensity (0–100 %)
106			Green	000–255	From OFF to high intensity (0–100 %)
107			Blue	000–255	From OFF to high intensity (0–100 %)
108			White	000–255	From OFF to high intensity (0–100 %)
109	Strip 5	Section 3	Dimmer	000–255	From OFF to high intensity (0–100 %)
110			Strobe	000–004	No function
				005–255	From low to high frequency
111			Red	000–255	From OFF to high intensity (0–100 %)
112			Green	000–255	From OFF to high intensity (0–100 %)
113			Blue	000–255	From OFF to high intensity (0–100 %)
114			White	000–255	From OFF to high intensity (0–100 %)
115	Strip 5	Section 4	Dimmer	000–255	From OFF to high intensity (0–100 %)
116			Strobe	000–004	No function
				005–255	From low to high frequency
117			Red	000–255	From OFF to high intensity (0–100 %)
118			Green	000–255	From OFF to high intensity (0–100 %)
119			Blue	000–255	From OFF to high intensity (0–100 %)
120			White	000–255	From OFF to high intensity (0–100 %)
121	Strip 6	Section 1	Dimmer	000–255	From OFF to high intensity (0–100 %)
122			Strobe	000–004	No function
				005–255	From low to high frequency
123			Red	000–255	From OFF to high intensity (0–100 %)
124			Green	000–255	From OFF to high intensity (0–100 %)
125			Blue	000–255	From OFF to high intensity (0–100 %)
126			White	000–255	From OFF to high intensity (0–100 %)
127	Strip 6	Section 2	Dimmer	000–255	From OFF to high intensity (0–100 %)
128			Strobe	000–004	No function
				005–255	From low to high frequency
129			Red	000–255	From OFF to high intensity (0–100 %)
130			Green	000–255	From OFF to high intensity (0–100 %)
131			Blue	000–255	From OFF to high intensity (0–100 %)
132			White	000–255	From OFF to high intensity (0–100 %)
133	Strip 6	Section 3	Dimmer	000–255	From OFF to high intensity (0–100 %)
134			Strobe	000–004	No function
				005–255	From low to high frequency
135			Red	000–255	From OFF to high intensity (0–100 %)
136			Green	000–255	From OFF to high intensity (0–100 %)
137			Blue	000–255	From OFF to high intensity (0–100 %)
138			White	000–255	From OFF to high intensity (0–100 %)
139	Strip 6	Section 4	Dimmer	000–255	From OFF to high intensity (0–100 %)

192 CH	Strip	Section	Function	Value	Setting
140			Strobe	000-004	No function
				005-255	From low to high frequency
141			Red	000-255	From OFF to high intensity (0-100 %)
142			Green	000-255	From OFF to high intensity (0-100 %)
143			Blue	000-255	From OFF to high intensity (0-100 %)
144			White	000-255	From OFF to high intensity (0-100 %)
145	Strip 7	Section 1	Dimmer	000-255	From OFF to high intensity (0-100 %)
146			Strobe	000-004	No function
				005-255	From low to high frequency
147			Red	000-255	From OFF to high intensity (0-100 %)
148			Green	000-255	From OFF to high intensity (0-100 %)
149			Blue	000-255	From OFF to high intensity (0-100 %)
150			White	000-255	From OFF to high intensity (0-100 %)
151	Strip 7	Section 2	Dimmer	000-255	From OFF to high intensity (0-100 %)
152			Strobe	000-004	No function
				005-255	From low to high frequency
153			Red	000-255	From OFF to high intensity (0-100 %)
154			Green	000-255	From OFF to high intensity (0-100 %)
155			Blue	000-255	From OFF to high intensity (0-100 %)
156			White	000-255	From OFF to high intensity (0-100 %)
157	Strip 7	Section 3	Dimmer	000-255	From OFF to high intensity (0-100 %)
158			Strobe	000-004	No function
				005-255	From low to high frequency
159			Red	000-255	From OFF to high intensity (0-100 %)
160			Green	000-255	From OFF to high intensity (0-100 %)
161			Blue	000-255	From OFF to high intensity (0-100 %)
162			White	000-255	From OFF to high intensity (0-100 %)
163	Strip 7	Section 4	Dimmer	000-255	From OFF to high intensity (0-100 %)
164			Strobe	000-004	No function
				005-255	From low to high frequency
165			Red	000-255	From OFF to high intensity (0-100 %)
166			Green	000-255	From OFF to high intensity (0-100 %)
167			Blue	000-255	From OFF to high intensity (0-100 %)
168			White	000-255	From OFF to high intensity (0-100 %)
169	Strip 8	Section 1	Dimmer	000-255	From OFF to high intensity (0-100 %)
170			Strobe	000-004	No function
				005-255	From low to high frequency
171			Red	000-255	From OFF to high intensity (0-100 %)
172			Green	000-255	From OFF to high intensity (0-100 %)
173			Blue	000-255	From OFF to high intensity (0-100 %)
174			White	000-255	From OFF to high intensity (0-100 %)
175	Strip 8	Section 2	Dimmer	000-255	From OFF to high intensity (0-100 %)
176			Strobe	000-004	No function
				005-255	From low to high frequency
177			Red	000-255	From OFF to high intensity (0-100 %)
178			Green	000-255	From OFF to high intensity (0-100 %)
179			Blue	000-255	From OFF to high intensity (0-100 %)

192 CH	Strip	Section	Function	Value	Setting
180			White	000–255	From OFF to high intensity (0–100 %)
181	Strip 8	Section 3	Dimmer	000–255	From OFF to high intensity (0–100 %)
182			Strobe	000–004	No function
				005–255	From low to high frequency
183			Red	000–255	From OFF to high intensity (0–100 %)
184			Green	000–255	From OFF to high intensity (0–100 %)
185			Blue	000–255	From OFF to high intensity (0–100 %)
186			White	000–255	From OFF to high intensity (0–100 %)
187	Strip 8	Section 4	Dimmer	000–255	From OFF to high intensity (0–100 %)
188			Strobe	000–004	No function
				005–255	From low to high frequency
189			Red	000–255	From OFF to high intensity (0–100 %)
190			Green	000–255	From OFF to high intensity (0–100 %)
191			Blue	000–255	From OFF to high intensity (0–100 %)
192			White	000–255	From OFF to high intensity (0–100 %)

6.7.11. Built-in Programs Channel Overview

Function	Value	Setting
Built-in programs	000–010	No function
	011–022	Program 2
	023–034	Program 3
	035–046	Program 4
	047–058	Program 5
	059–070	Program 6
	071–082	Program 7
	083–094	Program 8
	095–106	Program 9
	107–118	Program 10
	119–130	Program 11
	131–142	Program 12
	143–154	Program 13
	155–166	Program 14
	167–178	Program 15
	179–190	Program 16
	191–202	Program 17
	203–214	Program 18
	215–226	Program 19
	227–238	Program 20
239–255	Program 21	

6.7.12. Preset Colors Channel Overview

Function	Value	Setting
	000–005	Color 1
	006–011	Color 2
	012–017	Color 3
	018–023	Color 4
	024–029	Color 5
	030–035	Color 6
	036–041	Color 7
	042–047	Color 8
	048–053	Color 9
	054–059	Color 10
	060–065	Color 11
	066–071	Color 12
	072–077	Color 13
	078–083	Color 14
	084–089	Color 15
	090–095	Color 16
	096–101	Color 17
	102–107	Color 18
	108–113	Color 19
	114–119	Color 20
	120–125	Color 21
	126–131	Color 22
	132–137	Color 23
	138–143	Color 24
	144–149	Color 25
	150–155	Color 26
	156–161	Color 27
	162–167	Color 28
	168–173	Color 29
	174–179	Color 30
	180–185	Color 31
	186–191	Color 32
	192–197	Color 33
	198–203	Color 34
	204–209	Color 35
	210–215	Color 36
	216–221	Color 37
	222–227	Color 38
	228–233	Color 39
	234–255	Color 40

Preset colors

6.8. RDM Information

This device supports RDM (see [6.8.2. Supported RDM PIDs \(Parameter IDs\)](#)).

6.8.1. RDM Details

- Responder ID: 29B4:0F6XXXXX
- Manufacturer's ID: Showtec (Highlite International B.V.)
- Manufacturer Label: Showtec
- Model Description: Controller for Octostrip FLEX
- Model ID: 246 (0F6 hexadecimal)
- Device Label: Controller for Octostrip FLEX

Note:

An RDM responder ID consists of 3 parts:

- 1st part – 4 digits – Manufacturer's ID
- 2nd part – 3 digits – Model ID
- 3rd part – 5 digits – Unique ID

The RDM responder IDs of all products of Highlite International start with the same 4 digits. The first 7 digits of the RDM responder ID for each model are the same. The last 5 digits are different for each device.

6.8.2. Supported RDM PIDs (Parameter IDs)

Parameter ID	Value	Required	GET	SET
SUPPORTED_PARAMETERS	0x0050	*	*	
DEVICE_MODEL_DESCRIPTION	0x0080		*	
MANUFACTURER_LABEL	0x0081		*	
DEVICE_LABEL	0x0082		*	*
FACTORY_DEFAULTS	0x0090		*	*
DMX_PERSONALITY	0x00E0		*	*
DMX_PERSONALITY_DESCRIPTION	0x00E1		*	
DMX_START_ADDRESS	0x00F0	*	*	*
SENSOR_DEFINITION	0x0200		*	
SENSOR_VALUE	0x0201		*	*

7. Troubleshooting

This troubleshooting guide contains solutions to problems which can be carried out by an ordinary person. The device does not contain user-serviceable parts.

Unauthorized modifications to the device will render the warranty void. Such modifications may result in injuries and material damage.

Refer servicing to instructed or skilled persons. Contact your Highlite International dealer in case the solution is not described in the table.

Problem	Probable cause(s)	Solution
The device does not function at all	No power to the device	<ul style="list-style-type: none"> Make sure that the device is connected to the power supply and the cables are plugged in
	The internal fuse is blown	<ul style="list-style-type: none"> Disconnect the device and contact your Highlite International dealer
The device responds erratically	The factory settings of the device are changed	<ul style="list-style-type: none"> Reset the parameters of the device to the default factory settings (see 6.6.7. Settings on page 30)
The device does not respond to DMX control	The controller is not connected	<ul style="list-style-type: none"> Connect the controller
	The signal is reversed. The 5-pin DMX OUT of the controller does not match the DMX IN of the device	<ul style="list-style-type: none"> Install a phase-reversing cable between the controller and the device
	The controller is defective	<ul style="list-style-type: none"> Try using another controller
The device responds erratically to DMX control	Connections are defective	<ul style="list-style-type: none"> Examine connections and cables. Correct defective connections. Repair or replace damaged cables
	The data link is not terminated with a 120 Ω termination plug	<ul style="list-style-type: none"> Insert a termination plug in the DMX OUT connector of the last device on the link
	Incorrect addressing	<ul style="list-style-type: none"> Make sure that the address settings are correct
	Settings are not correct	<ul style="list-style-type: none"> Make sure that you have selected the correct settings in the Led Mode submenu (see 6.6.7.2. Led Mode on page 31)
	In case of a setup with multiple devices, one of the devices is defective and disturbs data transmission on the link	<ul style="list-style-type: none"> To find the defective device, bypass one device at a time until normal operation is restored
No light or LEDs cut out intermittently	LEDs are damaged	<ul style="list-style-type: none"> Disconnect the device and contact your Highlite International dealer
	The input power parameters of the device do not match local AC voltage and frequency	<ul style="list-style-type: none"> Disconnect the device. Make sure that the local current, voltage and frequency match the input voltage, current and frequency specified on the information label on the device

8. Maintenance

8.1. Safety Instructions for Maintenance



DANGER
Electric shock caused by dangerous voltage inside

Disconnect power supply before servicing or cleaning.

8.2. Preventive Maintenance



Attention
Before each use, examine the device visually for any defects.

Make sure that:

- All screws used for installing the device or parts of the device are tightly fastened and are not corroded.
- The safety devices are not damaged.
- There are no deformations on housings, fixings and installation points.
- The power cables are not damaged and do not show any material fatigue.

8.2.1. Basic Cleaning Instructions

To clean the device, follow the steps below:

- 01) Disconnect the device from the electrical power supply.
- 02) Allow the device to cool down for at least 5 minutes.
- 03) Remove the dust collected on the external surface with dry compressed air and a soft brush.



Attention

- Do not immerse the device in liquid.
- Do not use alcohol or solvents.

8.3. Corrective Maintenance

The device does not contain user-serviceable parts. Do not open the device and do not modify the device.

Refer repairs and servicing to instructed or skilled persons. Contact your Highlite International dealer for more information.

9. Deinstallation, Transportation and Storage

9.1. Instructions for Deinstallation

**WARNING**

Incorrect deinstallation can cause serious injuries and damage of property.

- Let the device cool down before dismantling.
- Disconnect power supply before deinstallation.
- Always observe the national and site-specific regulations during deinstallation and derigging of the device.
- Wear personal protective equipment in compliance with the national and site-specific regulations.

9.2. Instructions for Transportation

- Use the original packaging to transport the device, if possible.
- Always observe the handling instructions printed on the outer carton box, for example: "Handle with care", "This side up", "Fragile".

9.3. Storage

- Clean the device before storing (see [8.2. Preventive Maintenance](#) on page 66).
- Store the device in the original packaging, if possible.

10. Disposal

Correct disposal of this product



Waste Electrical and Electronic Equipment

This symbol on the product, its packaging or documents indicates that the product shall not be treated as household waste. Dispose of this product by handing it to the respective collection point for recycling of electrical and electronic equipment. This is to avoid environmental damage or personal injury due to uncontrolled waste disposal. For more detailed information about recycling of this product contact the local authorities or the authorized dealer.

11. Approval



Check the respective product page on the website of Highlite International (www.highlite.com) for an available declaration of conformity.

