



Electro-Voice



Performance beyond
the reach of the
competition.

BRAIN POWER

Intelligent technology,
innovative design.

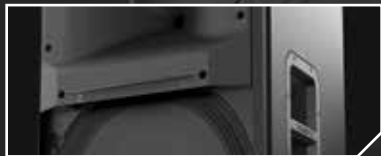

ETX

Performance beyond the reach of the competition.

BRAIN POWER

Intelligent technology, innovative design.



EV's FIR-Drive utilizes the latest Finite Impulse Response (FIR) filter technology to optimize transducer linearity. Advanced limiter algorithms for independent peak and thermal transducer protection.



Complete full-function DSP control via a single-knob interface. LCD screen for easy system set-up and monitoring: location/application EQ presets, limiter status, input level controls/meters and master volume control to ensure optimal gain structure. Subs feature a preset for true cardioid performance.



EV-patented Signal Synchronized Transducers (SST) waveguide design provides precise and consistent coverage across all system configurations. Waveguides are custom-designed and optimized per ETX model.

State-of-the-art components deliver the legendary EV sound quality and reliability the pros trust: 1800 W (subs) and 2000 W (full-range) Class-D power amplifiers with integrated DSP produce high SPLs utilizing high-sensitivity, low-distortion transducers (including DVX and SMX series woofers and 1.25-inch HF titanium compression drivers).



Lightweight, durable and compact 18-mm, 13-ply birch plywood enclosures finished with EVCoat. Eight mounting points for permanent installations (two-way models). Custom die-cast aluminum pole cups, handles and hardware.



Designed, engineered and tested for ultimate reliability by Electro-Voice in the USA.

ETX PROFESSIONAL PORTABLE POWERED LOUDSPEAKERS

ETX-12P

ETX-15P

ETX-35P

ETX-15SP

ETX-18SP

ETX-10P

The new ETX family builds upon the industry-leading innovation and 85-year heritage of Electro-Voice audio engineering to offer the most advanced professional portable powered loudspeakers available today.

A versatile high-end choice for live entertainment venues, rental companies, pro musicians and DJs, and installed sound, the ETX family features three two-way models (10-inch, 12-inch and 15-inch, all with a 1.25-inch HF titanium compression driver), a three-way model (15-inch with a 6.5-inch MF driver and a 1.25-inch HF titanium compression driver) and two subs (15-inch and 18-inch drivers).

Positioned above the ZLX and Live X families respectively, ETX completes a trio of recent EV portable loudspeaker offerings—each of which was designed to bring best-in-class performance to its price point.

Inside each low-profile, tour-grade wood enclosure are a host of unique new features that set ETX apart, combining intelligent technology and innovative industrial design for spectacular results across all applications. EV-engineered high-efficiency transducers and high-powered Class-D amplifiers, Signal Synchronized Transducers (SST) waveguide design and smart FIR-Drive DSP all work together to provide peerless EV sound quality and precise coverage at the highest SPLs.

SIGNAL SYNCHRONIZED TRANSDUCERS (SST) WAVEGUIDE DESIGN

- Unique to the industry, with multiple design and utility patents.
- Third generation (after Tour X FM and ZLX models).
- Waveguides custom-designed and optimized per ETX model.
 - This allows EV to design the waveguide to have uniform beamwidth response throughout the waveguide's passband and allows a smooth transition between woofer beamwidth and waveguide beamwidth.
 - This also allows EV to use much larger waveguides without making the speaker larger.
 - This optimization also achieves a flat sound power—critical to great sound in any application.
- The waveguide is placed forward in the enclosure to help physically time-align the LF and HF transducers, minimizing the need for latency correction via DSP.
- Placing the port under the waveguide positions it in its ideal acoustic location in the enclosure without spacing the woofer and driver apart. The port location minimizes distortion and standing waves inside the loudspeaker.
- All waveguides are optimized using advanced simulation software and proprietary algorithms for precise control and lowest distortion.

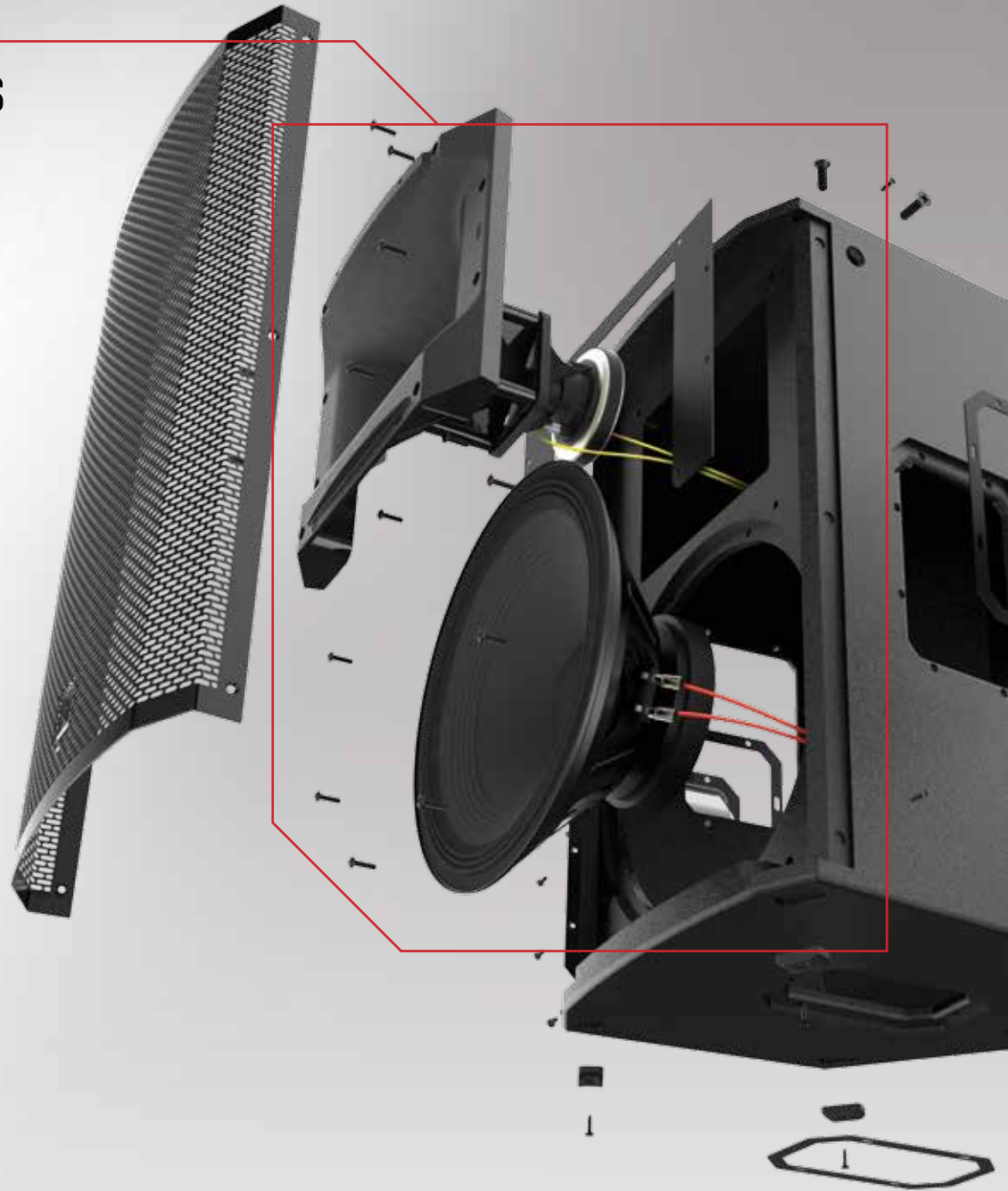

HIGH-SENSITIVITY, LOW-DISTORTION TRANSDUCER DESIGN

- EV focuses on creating high-sensitivity woofers and compression drivers that have linear frequency response and high power handling (competitors use smaller motor designs to save cost).
- The small diaphragm, convex-loaded phase plug and tight manufacturing tolerances of the DH3-B allows for high frequency extension to 20 kHz and beyond, and the high-sensitivity design achieves maximum SPL requirements similar to competitive large-format compression drivers.
- The motor designs are optimized using advanced modeling software and tested extensively, ensuring the transducers have low distortion at full output.



- All ETX woofers use Faraday rings for significantly better vocal reproduction.
- The woofers not only have high power handling but also feature a robust mechanical design to ensure long-term reliability.
- EV focuses on engineering transducers with linear frequency response, minimizing the need for additional equalization.

PROFESSIONAL-GRADE COMPONENTS AND TESTING



- All ETX components are designed from the ground up by Electro-Voice. No off-the-shelf components are used.
- The handles, pole cups and amplifier chassis are die-cast aluminum, not plastic.
- 18-mm, 13-ply birch plywood with EVCoat is used throughout the product line, a combination that offers best-in-class looks and durability.
- In addition to industry-standard pink noise abuse tests, all models must survive EV's proprietary 1000-hour torture test that uses real-world signals driven beyond full output.



BEST-IN-CLASS PROCESSING AND CONTROL

- System DSP presets support quick and easy setup via selections for type of use, crossover frequencies and top/sub combinations.
- Subwoofers include a DSP preset for “true cardioid” configuration.
- ETX employs the same proprietary PAL and TEMP limiters developed for our concert loudspeakers.
 - Not all limiters are created equal: EV spends a lot of design effort on making sure its processing is as acoustically transparent as possible.
 - The limiters are displayed on the rear LCD and on the front-grille LED.
- ETX also uses the same proprietary FIR-Drive that was developed for our concert loudspeakers. The filters are linear phase and use extremely steep crossover slopes.



- Boundary compensation filters are included so that an ETX loudspeaker sounds the same whether it is used as a floor monitor, on a tripod or suspended from a ceiling.
- ETX offers user-adjustable features not found on any other loudspeakers in this class, including delay out to several hundred feet, three-band parametric equalization, polarity and multiple high-pass crossover points.
- The Class-D design of the amplifier is highly efficient and features blower-controlled thermal management, allowing it to work in hot environments. The fan is of a very quiet design and does not turn on under normal circumstances.
- Lockout mode helps prevent casual users from changing settings.



10

ETX-10P



10" TWO-WAY POWERED LOUDSPEAKER

- 10-inch LF SMX woofer
- 1.25-inch HF titanium compression driver
- 2000 W Class-D power amplifier with integrated FIR-Drive DSP
- 134 dB peak SPL

ETX-12P

12



12" TWO-WAY POWERED LOUDSPEAKER

- 12-inch LF SMX woofer
- 1.25-inch HF titanium compression driver
- 2000 W Class-D power amplifier with integrated FIR-Drive DSP
- 135 dB peak SPL

15

ETX-15P

ETX-35P

15 3-WAY



15" TWO-WAY POWERED LOUDSPEAKER

- 15-inch LF SMX woofer
- 1.25-inch HF titanium compression driver
- 2000 W Class-D power amplifier with integrated FIR-Drive DSP
- 135 dB peak SPL

15" THREE-WAY POWERED LOUDSPEAKER

- 15-inch LF SMX woofer
- 6.5-inch MF driver
- 1.25-inch HF titanium compression driver
- 2000 W Class-D power amplifier with integrated FIR-Drive DSP
- 136 dB peak SPL

15 SUB

ETX-15SP



15" POWERED SUBWOOFER

- 15-inch DVX woofer for maximum punch
- 1800 W Class-D power amplifier with integrated FIR-Drive DSP
- 134 dB peak SPL
- Special DSP preset for true cardioid performance across the full operating bandwidth
- Combo pole cup (insert and threaded) for use with the ETX two-way models
- Removable casters

ETX-18SP

18 SUB



18" POWERED SUBWOOFER

- 18-inch DVX woofer for extended low-frequency response
- 1800 W Class-D power amplifier with integrated FIR-Drive DSP
- 135 dB peak SPL
- Special DSP preset for true cardioid performance across the full operating bandwidth
- Combo pole cup (insert and threaded) for use with the ETX two-way models
- Removable casters

ETX TECHNICAL SPECIFICATIONS



ETX-10P



ETX-12P



ETX-15P



ETX-35P

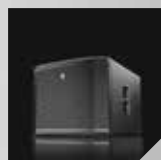

ETX-15SP



ETX-18SP

Frequency Response:	85 Hz – 20 kHz ¹	55 Hz – 20 kHz ¹	48 Hz – 20 kHz ¹	48 Hz – 20 kHz ¹	37 Hz – 150 Hz ²	33 Hz – 150 Hz ²
Frequency Range:	65 Hz – 20 kHz ¹	43 Hz – 20 kHz ¹	40 Hz – 20 kHz ¹	38 Hz – 20 kHz ¹	32 Hz – 180 Hz ²	28 Hz – 180 Hz ²
Maximum SPL:	134 dB peak ³	135 dB peak ³	135 dB peak ³	136 dB peak ³	134 dB peak ³	135 dB peak ³
Coverage (H x V):	90° x 60°	90° x 60°	90° x 60°	60° x 40°		
Power Rating:	2000 W	2000 W	2000 W	2000 W	1800 W	1800 W
LF Transducer:	SMX2100 254 mm (10 in)	SMX2120 300 mm (12 in)	SMX2150 380 mm (15 in)	SMX2151 380 mm (15 in)	DVX3159A 380 mm (15 in)	DVX3180A 457 mm (18 in)
MB Transducer:				EVS-6C 6.5-in mid-bass driver		
HF Transducer:	DH3-B 1.25-in titanium compression driver					
Crossover Frequency:	1700 Hz	1600 Hz	1500 Hz	700 Hz, 2900 Hz		
Low Pass Frequency:					Adjustable: 80 Hz, 100 Hz, 120 Hz, 150 Hz	
Connectors:	(2) XLR/TRS combo jack and (1) XLR link output				(2) XLR/TRS Combo Jack and (2) XLR link Output	
Enclosure:	18-mm, 13-ply birch plywood with EVCoat					
Grille:	16AWG steel with powdercoat					
Suspension:	(8) M10 suspension points					
Dimensions (H x W x D):	21 in x 13 in x 14 in (526 mm x 330 mm x 365 mm)	24 in x 15 in x 16 in (613 mm x 381 mm x 400 mm)	27 in x 17 in x 18 in (691 mm x 431 mm x 447 mm)	40 in x 18 in x 17 in (1023 mm x 469 mm x 426 mm)	19 in x 23 in x 32 in (471 mm x 576 mm x 825 mm)	22 in x 27 in x 36 in (550 mm x 675 mm x 910 mm)
					<i>Without casters:</i> 19 in x 23 in x 27 in (471 mm x 576 mm x 692 mm)	<i>Without casters:</i> 22 in x 27 in x 31 in (550 mm x 675 mm x 777 mm)
Net Weight:	44.8 lb (20.3 kg)	52.0 lb (23.6 kg)	61.1 lb (27.7 kg)	84.2 lb (38.2 kg)	91.9 lb (41.7 kg)	114.2 lb (51.8 kg)
Shipping Weight:	50.5 lb (22.9 kg)	59.1 lb (26.8 kg)	69.5 lb (31.5 kg)	94.4 lb (42.8 kg)	103.2 lb (46.8 kg)	129.9 lb (58.9 kg)
Power Consumption:	100 – 240 V~, 50 – 60 Hz, 1.6 – 0.8 A ⁴					

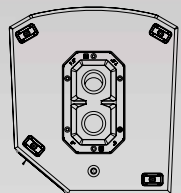
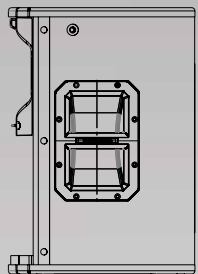
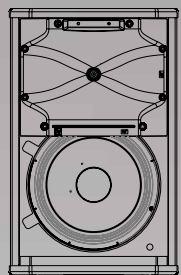
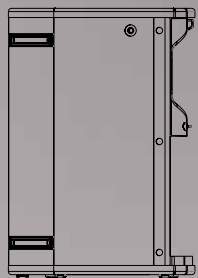

¹Full space measurement using the music DSP preset and 150 Hz low pass. ²Half space measurement using the music DSP preset and 150 Hz low pass. ³Maximum SPL is measured at 1 m using broadband pink noise at maximum output. ⁴Current rating is 1/8 power.

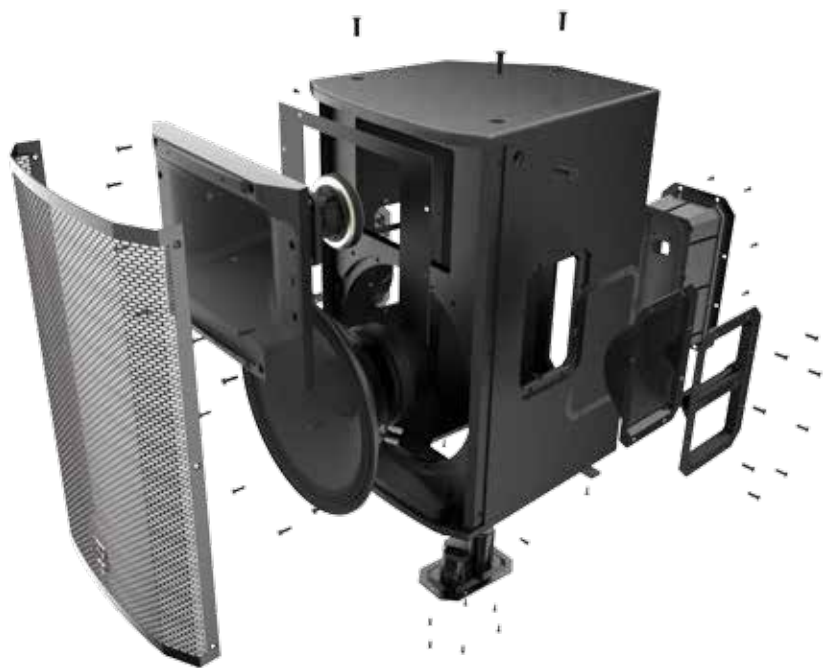

Electro-Voice